

Job Name: _____
 System Reference: _____ Date: _____



UNIT OPTION

- Standard Model.....PUHY-P336YSLMU-A
- Seacoast (BS) Model.....PUHY-P336YSLMU-A-BS

ACCESSORIES

- Twinning Kit (required).....CMY-Y300CBK2
- Joint Kit.....for details see Pipe Accessories Submittal
- Low Ambient Kitfor details see Low Ambient Kit Submittal
- Snow/Hail Guards Kit.....for details see Snow/Hail Guards Kit Submittal
- Base Pan Heater Kit.....for details see Base Pan Heater Kit Submittal

Specifications		System	Module 1	Module 2	Module 3
Unit Type		PUHY-P336YSLMU-A (-BS)	PUHY-P120YLMU-A (-BS)	PUHY-P120YLMU-A (-BS)	PUHY-P96YLMU-A (-BS)
Nominal Cooling Capacity (460V)	Btu/h	336,000	120,000	120,000	96,000
Nominal Heating Capacity (460V)	Btu/h	378,000	135,000	135,000	108,000
Operating Temperature Range *1	Cooling (Outdoor) *2	Refer to Module Data	23~126° F (-5~52° C) DB		
	Heating (Outdoor)		-13~60° F (-25~15.5° C) WB		
External Dimensions (H x W x D)	In. (mm)	Refer to Module Data	64-31/32 x 68-29/32 x 29-5/32 (1,650 x 1,750 x 740)	64-31/32 x 68-29/32 x 29-5/32 (1,650 x 1,750 x 740)	64-31/32 x 48-1/16 x 29-5/32 (1,650 x 1,220 x 740)
Net Weight	Lbs. (kg)	1,944 (881)	706 (320)	706 (320)	532 (241)
External Finish		Refer to Module Data	Pre-coated galvanized steel sheet		
Electrical Power Requirements	Voltage, Phase, Hertz	Refer to Module Data**	460V, 3-Phase, 60Hz		
Minimum Circuit Ampacity (MCA)	A	Refer to Module Data**	19	19	14
Maximum Overcurrent Protection (MOP)	A	Refer to Module Data**	30	30	20
<i>Piping Diameter (Braze)</i>					
From Twinning Kit to First Joint or Header (In. / mm)	Liquid (High Pressure)	3/4 (19.05)	Refer to System Data		
	Gas (Low Pressure)	1-5/8 (41.28)			
Max. Total Refrigerant Line Length	Ft.	3,280	Refer to System Data		
Max. Refrigerant Line Length (Between ODU & IDU)	Ft.	541			
Max. Control Wiring Length	Ft.	1,640			
Indoor Unit	Total Capacity	50~130% of outdoor unit capacity	Refer to System Data		
	Model / Quantity	P06~P96/2~50	Refer to System Data		
Sound Pressure Level	dB(A)	64.5	Refer to System Data		
<i>Fan</i>					
Type x Quantity		Refer to Module Data	Propeller fan x 2	Propeller fan x 2	Propeller fan x 1
Airflow Rate	CFM		11,300	11,300	6,700
External Static Pressure	In. WG	Refer to Module Data	Selectable; 0, 0.12 or 0.24"WG; factory set to 0"W.G.		
Compressor Operating Range		3% to 100%	Refer to System Data		
Compressor Type x Quantity		Refer to Module Data	Inverter-driven Scroll Hermetic x 1	Inverter-driven Scroll Hermetic x 1	Inverter-driven Scroll Hermetic x 1
Refrigerant		Refer to Module Data	R410A; 26 lbs. + 1 oz. (11.8 kg)	R410A; 26 lbs. + 1 oz. (11.8 kg)	R410A; 22 lbs. + 12 oz. (10.3 kg)
Protection Devices	High Pressure	Refer to Module Data	High pressure sensor, High pressure switch at 4.15 MPa (601 psi)	High pressure sensor, High pressure switch at 4.15 MPa (601 psi)	High pressure sensor, High pressure switch at 4.15 MPa (601 psi)
	Inverter Circuit (Comp. / Fan)		Over-current protection	Over-current protection	Over-current protection
AHRI Ratings (Ducted/Non-Ducted)	EER	11.8 / 13.2	Refer to System Data		
	IEER	20.3 / 23.4			
	COP	3.43 / 3.52			

NOTES:
 *1. When applying product below -4° F, consult your design engineer for cold climate application best practices, including the use of a backup source for heating.
 *2. For details on extended cooling operation range down to -10° F DB, see Low Ambient Kit Submittal.
 ** Each individual module requires a separate electrical connection. Refer to electrical data for each individual module.

Outdoor Unit: PUHY-P336YSLMU-A (-BS) – DIMENSIONS

Unit : mm (in.)

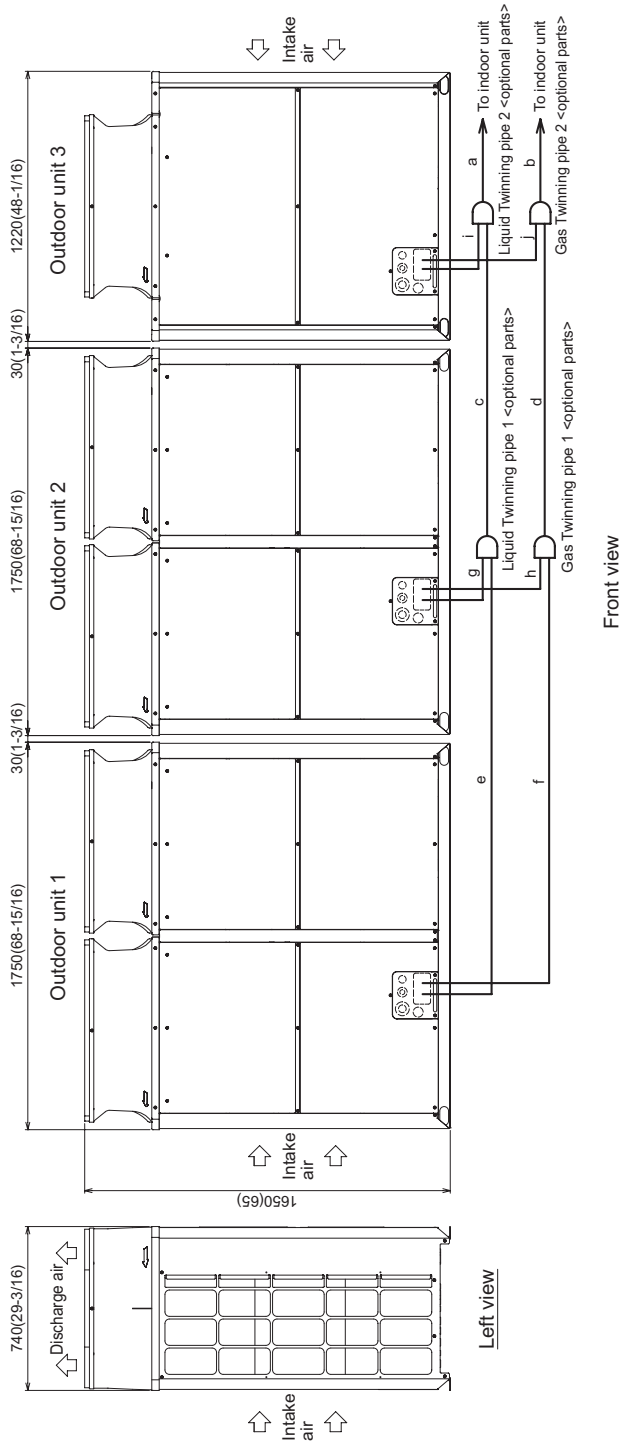

Front view

Left view

Twinning pipe connection size		Package unit name	PUHY-P336YSLMU-A(-BS)
Component unit name	Outdoor unit 1	PUHY-P120YLMU-A(-BS)	
	Outdoor unit 2	PUHY-P120YLMU-A(-BS)	
	Outdoor unit 3	PUHY-P96YLMU-A(-BS)	
Outdoor Twinning Kit(optional parts)		CMY-Y300CBK2	
Indoor unit~Twinning pipe 2	Liquid a	ø19.05(3/4)	
	Gas b	ø41.28(1-5/8)	
Twinning pipe 1~Twinning pipe 2	Liquid c	ø19.05(3/4)	
	Gas d	ø34.93(1-3/8)	

Unit model	Liquid e or g or i	Gas f or h or j
P36	ø9.52(3/8)	ø22.2(7/8)
P120	ø12.7(1/2)	ø28.58(1-1/8)

- Note 1. Connect the pipes as shown in the figure above. Refer to the table above for the pipe size.
 2. Twinning pipes should not be tilted more than 15 degrees from the horizontal plane.
 Be sure to see the Installation Manual for details of Twinning pipe installation.
 3. The pipe section before the Twinning pipe (sections "a", "b", "c" and "d" in the figure) must have at least 500mm(19-11/16) of straight section (*including the straight pipe that is supplied with the Twinning pipe).
 4. Only use the Twinning pipe by Mitsubishi (optional parts).

NOTES:

SEACOAST PROTECTION

- Anti-corrosion Protection: A coating treatment is applied to condenser coil for protection from air contaminants.
- Standard: Salt Spray Test Method - no unusual rust development to 480 hours.
- Sea Coast (BS): Salt Spray Test Method (JRA 9002) - no unusual rust development to 960 hours.

Modules 1 & 2: PUHY-P120YLMU-A (-BS) – DIMENSIONS

Unit : mm (in.)

Note1. Please refer to the engineering manual for information regarding necessary spacing around the unit and foundation work. Outdoor unit must be mounted at least 12" off the ground or 12" above the highest average snow depth, whichever is greater.
2. At brazing of pipes, wrap the refrigerant service valve with wet cloth and keep the temperature of refrigerant service valve under 120°C(248 °F).

Connecting pipe specifications

Model	Refrigerant pipe		Diameter	
	Liquid	Gas	Liquid	Gas
PUHY-P120YLMU	ø9.52 Braze (3/8)2 (ø12.7 Braze) (1/2)1*3*4	ø26.58 Braze (1-1/8)1	ø12.7 (1/2)	ø28.58 (1-1/8)
PUHY-P144YLMU	ø12.7 Braze (1/2)1			
PUHY-P168YLMU	ø15.88 Braze (5/8)2			

*1 Expand the on-site piping and connect to the refrigerant service valve piping.
*2 Use the pipe joint(field supply) and connect to the refrigerant service valve piping.

*3 Indicates dimensions and connection specifications in the case the unit is used in combination with other outdoor units.

*4 Furthest piping length (OU from LU) ≥ 40m(131ft)

NO	Usage	Specifications
①	For pipes	Front through hole 140 x 77 Knockout hole (5-9/16) (3-1/16)
②		Bottom through hole 150 x 94 Knockout hole (5-15/16) (3-3/4)
③	For wires	Front through hole ø62.7 or ø34.5 Knockout hole (2-1/2) (1-3/8)
④		Front through hole ø43.7 or ø22.2 Knockout hole (1-3/4) (7/8)
⑤		Bottom through hole ø65 Knockout hole (2-9/16)
⑥		Bottom through hole ø52 Knockout hole (2-1/16)
⑦	For transmission cables	Front through hole ø34 Knockout hole (1-3/8)

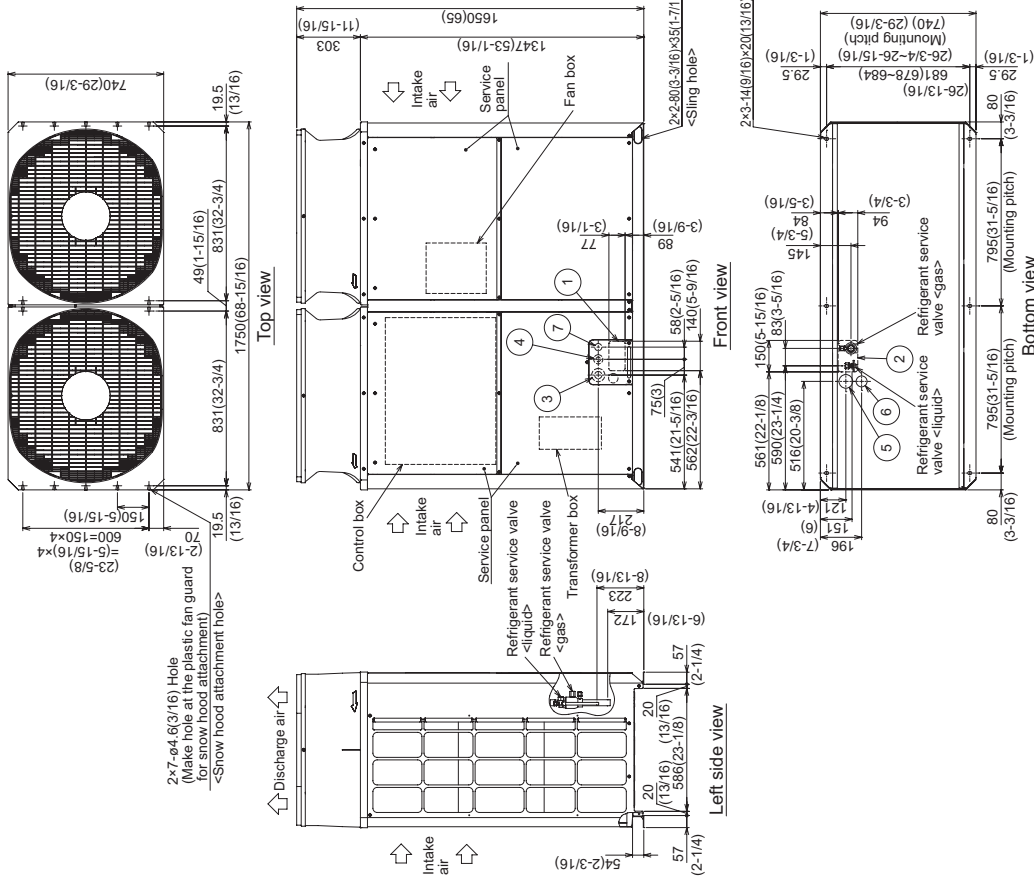

NOTES:

SEACOAST PROTECTION

- Anti-corrosion Protection: A coating treatment is applied to condenser coil for protection from air contaminants.
- Standard: Salt Spray Test Method - no unusual rust development to 480 hours.
- Sea Coast (BS): Salt Spray Test Method (JRA 9002) - no unusual rust development to 960 hours.

Model: PUHY-P96YLMU-A (-BS) – DIMENSIONS

Unit : mm (in.)

Note 1. Please refer to the engineering manual for information regarding necessary spacing around the unit and foundation work. Outdoor unit must be mounted at least 12" off the ground or 12" above the highest average snow depth, whichever is greater.
2. At brazing of pipes, wrap the refrigerant service valve with wet cloth and keep the temperature of refrigerant service valve under 120°C(248 °F).

Connecting pipe specifications

Model	Refrigerant pipe		Diameter	
	Liquid	Gas	Liquid	Gas
PUHY-P96YLMU	ø9.52 Braze (3/8)"1 (ø12.7 Braze) (1/2)"2 3	ø22.2 Braze (7/8)"2	ø9.52 (3/8)	ø28.58 (1-1/8)

*1 Expand the on-site piping and connect to the refrigerant service valve piping.
*2 Use the pipe joint (field supply) and connect to the refrigerant service valve piping.
*3 Furthest piping length (OU from IU) ≥ 90m(295ft)

NO	Usage	Specifications
①	Front through hole	140 x 77 Knockout hole (5-9/16) (3-1/16)
②	Bottom through hole	150 x 94 Knockout hole (5-15/16)(3-3/4)
③	Front through hole	ø62.7 or ø34.5 Knockout hole (2-1/2) (1-3/8)
④	Front through hole	ø43.7 or ø22.2 Knockout hole (1-3/4) (7/8)
⑤	Bottom through hole	ø65 Knockout hole (2-9/16)
⑥	Bottom through hole	ø52 Knockout hole (2-1/16)
⑦	For transmission cables	ø34 Knockout hole (1-3/8)

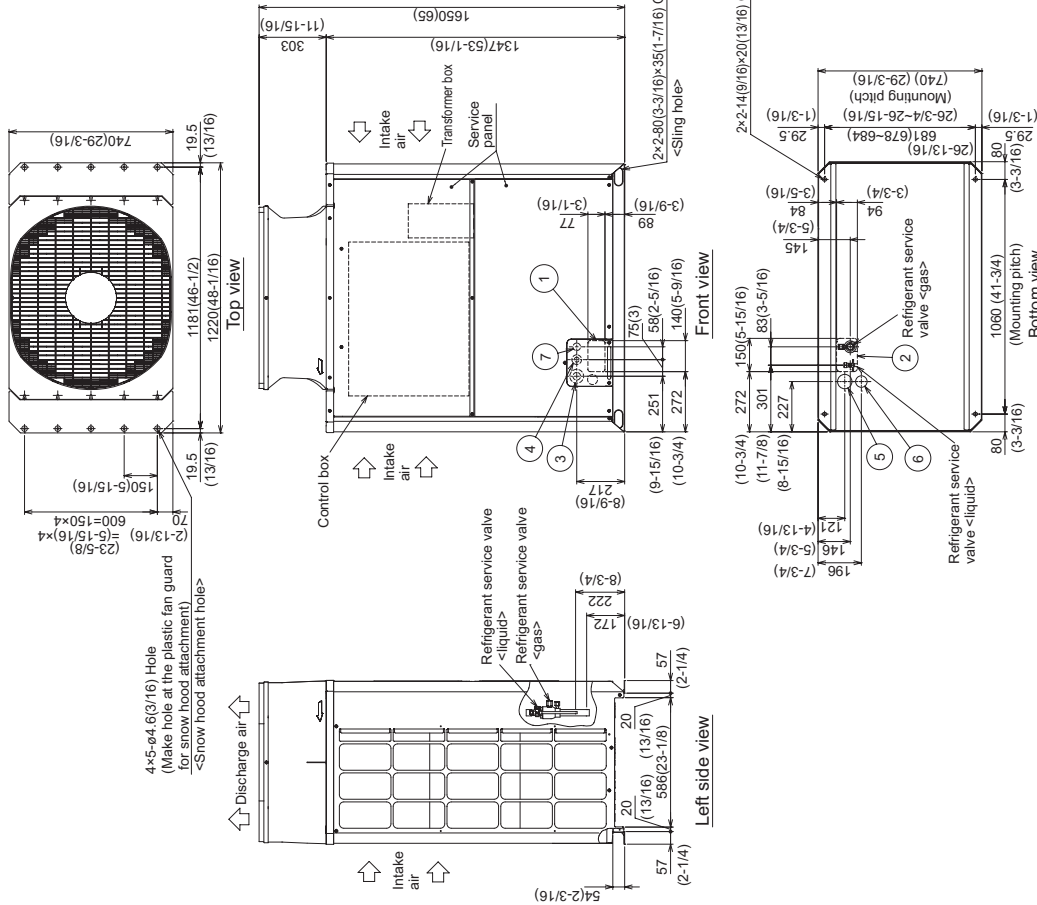

NOTES:

SEACOAST PROTECTION

- Anti-corrosion Protection: A coating treatment is applied to condenser coil for protection from air contaminants.
- Standard: Salt Spray Test Method - no unusual rust development to 480 hours.
- Sea Coast (BS): Salt Spray Test Method (JRA 9002) - no unusual rust development to 960 hours.

Twinning Kit: CMY-Y300CBK2

Ref.: CMY_Y300VBK2_EXD_EUDB_Si
in.

CMY-Y300CBK2

For Gas pipe:

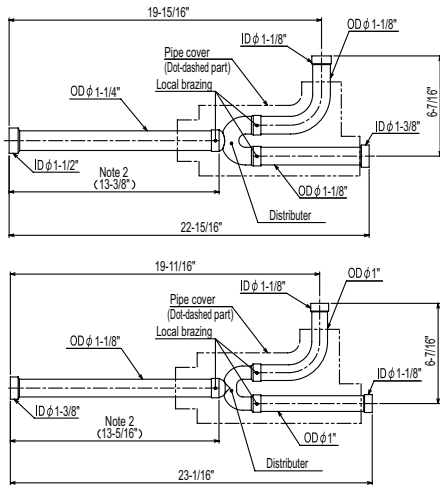

For Liquid pipe:

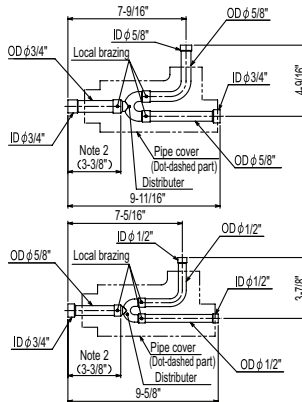

<Reducer(Accessory)>

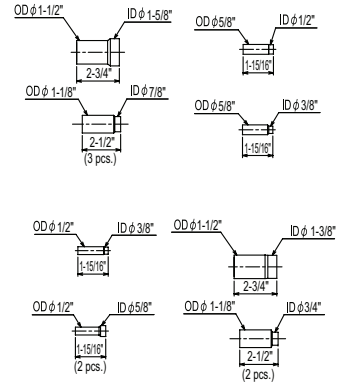

ID: Inner Diameter OD: Outer Diameter

Note 1. Reference the attitude angle of the branch pipe below the fig.

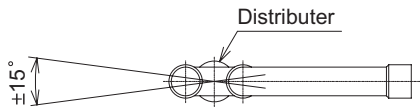

The angle of the branch pipe for high pressure is within $\pm 15^\circ$ against the horizontal plane.

2. Use the attached pipe to braze the port-opening of the distributor.
3. Pipe diameter is indicated by inside diameter.
4. Only use the Twinning pipe by Mitsubishi (optional parts).



COOLING & HEATING

1340 Satellite Boulevard, Suwanee, GA 30024
Toll Free: 800-433-4822 www.mehvac.com

