

Job Name:

System Reference:

Date:

**FEATURES**

- Single modules up to 20 tons with the ability to combine single modules for systems up to 30 tons
- 208/230V, 3-Phase, 60Hz and 460V, 3-Phase, 60Hz options
- Designed for closed water loops
- 0-10V output signal to modulate water flow for compliance with energy codes
- Features Variable Evaporating Temperature (VET) technology, which enables the outdoor unit to raise the target evaporation temperature based on the difference between set point and return air temperature, saving energy.
- Water flow can be stopped while the unit is in a thermo-off state, saving on pump energy consumption. For twinned systems, both modules must be thermo-off to stop water flow.
- Enhanced water-side heat exchanger design for improved efficiency and reduced risk of clogging
- Self-cooling cabinet design
- Inlet water temperature range: 23-113° F
- Max. Total Refrigerant Piping Length: 984' (P72,96,120), 1,640' (P144,168,192,216,240,264,288,312,336,360)
- Connects to CITY MULTI® indoor units; controlled via CITY MULTI® Controls Network (CMCN)
- External finish: Acrylic-painted steel
- Stack multiple units on a field-supplied rack to take advantage of vertical space when available
- Extended 10-year parts and compressor warranty available

**ACCESSORIES**

- Joint Kit (for details see Pipe Accessories Submittal)
- Header Kit (for details see Pipe Accessories Submittal)

## SPECIFICATIONS: PQHY-P72YLMU-A1

Specifications		Model Name	
Unit Type		PQHY-P72YLMU-A1	
Nominal Cooling Capacity (208/230V)	Btu/h	72,000	
Nominal Heating Capacity (208/230V)	Btu/h	80,000	
Operating Temperature Range	Cooling (Indoor)	W.B.	59~75° F (15~24°C)
	Heating (Indoor)	D.B.	59~81° F (15~27°C)
Operating Water Temperature Range	Cooling	°F	50~113° F (4~45° C)
	Heating	°F	50~113° F (4~45° C)
External dimension H x W x D	In.	43-5/16 x 34-11/16 x 21-11/16	
	mm	1,100 x 880 x 550	
Net weight	lbs. (kg)	400 (181)	
External finish		Galvanized steel sheets	
Electrical Power Requirements	Voltage, Phase, Hertz		460V, 3-phase, 60Hz
Minimum Circuit Ampacity	A	6	
Maximum Overcurrent Protection	A	15	
<b>Circulating Water (quality must meet regulations)</b>			
Flow Rate	G/min (gpm)	25.4	
	L/s	1.6	
Pressure Drop	Ft.	8.0	
	psi	3.48	
Operation Volume Range	G/min (gpm)	13.2 ~ 31.7	
	L/m	50 ~ 120	
Maximum Water Pressure	MPa	2	
	psi	290	
Water-source Connection for Inlet and Outlet	In.	1-1/2 NPT	
Piping Diameter (Brazed)	Liquid (High Pressure)	In. (mm)	3/8 (9.52)
	Gas (Low Pressure)	In. (mm)	3/4 (19.05)
Max. Total Refrigerant Line Length	Ft.	984	
Max. Refrigerant Line Length (Between ODU & IDU)	Ft.	541	
Max. Control Wiring Length	Ft.	1,640	
Indoor Unit	Total capacity		50~130% of heatsource unit capacity
	Model/Quantity		P06~P96/1~15
Sound pressure level (measured in anechoic room)	dB(A)	46	
Compressor Operating Range	24% - 100%		
Compressor Type x Quantity	Inverter scroll hermetic compressor x 1		
Motor output	kW	4.3	
Lubricant	MEL32		
Refrigerant	R410A x 11 lbs. + 1 oz. (5.0 kg)		

## SPECIFICATIONS: PQHY-P72YLMU-A1

Specifications		Model Name
Unit Type		PQHY-P72YLMU-A1
Protection Devices	High pressure protection	High pressure sensor, High pressure switch at 4.15 MPa (601 psi)
	Inverter circuit	Over-heat protection, Over-current protection
	Compressor	Over-heat protection
AHRI Ratings ( Ducted/Non-Ducted)	EER	17.4 / 20.7
	IEER	24.2 / 28.1
	COP	5.62 / 6.15

Notes:

# DIMENSIONS: PQHY-P72YLMU-A1

- Note1. Seal around the water piping, the refrigerant piping, the power supply, and the control wiring and plug unused knockout holes with putty, etc., to prevent moisture or dirt from entering cabinet.
- Note2. At the time of product shipment, the front side piping serves as the local drainage connection. When connecting on the rear side, please remove the rear side plug sealing corks, and attach on the front side. Ensure there is no leak in piping system once connected.
- Note3. See Fig. A and Fig. B for service clearances.
- Note4. If piping is installed in front of the unit, provide clearances as shown in Fig. A and Fig. B.
- Note5. Environmental condition for installation: -20~40°C(DB) (-4~104°F) for indoor installation.
- Note6. In case the temperature around the heat source unit has possibility to drop under 0°C(32°F), be careful for the following point to prevent the pipe burst by the water pipe freeze-up.  
 • Circulate the water all the time even if heat source unit is not in operation and provide glycol for freeze protection.  
 • Drain the water from inside of the heat source unit when the heat source unit will not operate for a long term.
- Note7. Ensure that the drain piping is downward with a pitch of more than 1/100.
- Note8. At brazing of pipes, wrap the refrigerant service valve with wet cloth and keep the temperature of refrigerant service valve under 120°C(248°F).

Unit : mm(in)

<Accessories>

- Refrigerant (Liquid) conn. pipe ..... 1pc.  
(P72/P96/P120 ; Packaged in the accessory kit)
- Refrigerant (Gas) conn. elbow ..... 1pc.  
(P72/P96/P120 ; Packaged in the accessory kit)
- Water stopper(Liquid,Gas) ..... 1pc. each  
(P72/P96/P120 ; Packaged in the accessory kit)
- Sealing material for water stopper (Liquid,Gas) ..... 1pc. each  
(P72/P96/P120 ; Packaged in the accessory kit)
- Sealing material for field piping (Liquid,Gas) ..... 1pc. each  
(P72/P96/P120 ; Packaged in the accessory kit)
- Sealing material for drain socket ..... 1pc.  
(P72/P96/P120 ; Packaged in the accessory kit)
- Pipe cover for gas ..... 1pc.  
(P72/P96/P120 ; Packaged in the accessory kit)

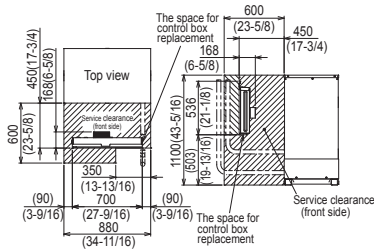
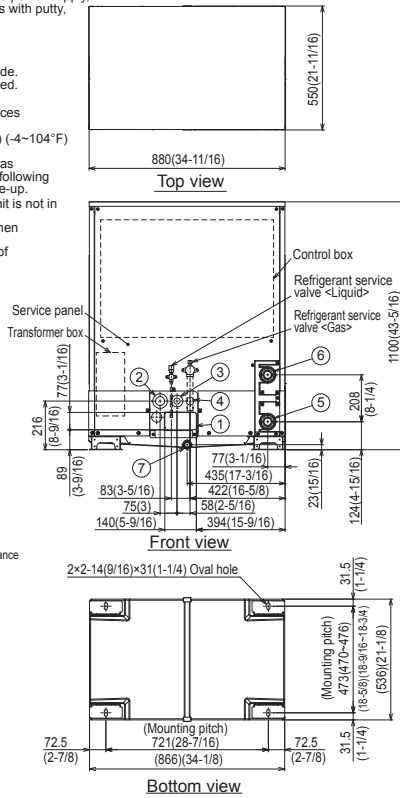

Fig. B

Connecting pipe specifications

Model	Refrigerant pipe		Service valve	
	Liquid	Gas	Liquid	Gas
PQHY-P72YLMU-A1	ø9.52 Brazeed (3/8)" 1	ø19.05 Brazeed (3/4)" 1 1/4		
PQHY-P96YLMU-A1	ø9.52 Brazeed (3/8)" 1	ø22.2 Brazeed (7/8)" 1 1/4	ø9.52 (3/8)	ø25.4 (1)
PQHY-P120YLMU-A1	ø9.52 Brazeed (3/8)" 1	ø12.7 Brazeed (1/2)" 1 1/4		

- \*1. Connect by using the connecting pipes and elbow that are supplied.  
 \*2. Total length ≥ 90m(295ft)  
 \*3. Total length ≥ 40m(131ft)  
 \*4. Use the pipe joint(field supply) and connect to the refrigerant service valve piping.



Top of unit casing not suitable for supporting system modules stacked above - field framing required for stacking modules of additional systems

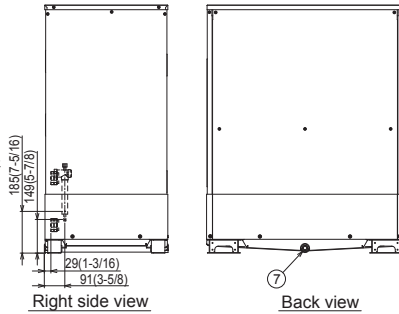

NO.	Usage	Specifications
①	For pipes	Front through hole 140 × 77 Knockout hole (5-9/16) (3-1/16)
②	For wires	Front through hole ø62.7 or ø34.5 Knockout hole (2-1/2) (1-3/8)
③		Front through hole ø43.7 or ø22.2 Knockout hole (1-3/4) (7/8)
④	For transmission cables	Front through hole ø34 Knockout hole (1-3/8)
⑤	Water pipe inlet	NPT1-1/2 Screw (1-3/8)
⑥	Water pipe outlet	NPT1-1/2 Screw (1-3/8)
⑦	Drain pipe	Rc3/4 Screw

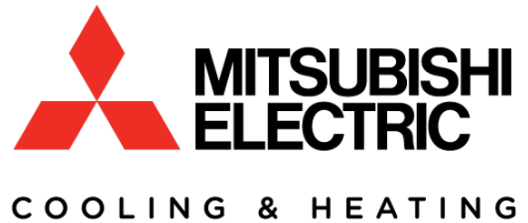

1340 Satellite Boulevard, Suwanee, GA 30024  
Toll Free: 800-433-4822 www.mehvac.com



FORM# PQHY-P72YLMU-A1 - 201708

Specifications are subject to change without notice.

Copyright © 2017 Mitsubishi Electric US, Inc.