

**40VMD**  
**Multiport Distribution Controller (MDC) for**  
**Variable Refrigerant Flow (VRF) System**

---

# Engineering Data Book



# Table of Contents

I.	Multiport Distribution Controller (MDC) Basic Information.....	3
1.	Specifications.....	3
2.	Accessories .....	12
II.	Dimensions .....	13
III.	Wiring Diagrams .....	22
IV.	Refrigerant Circuit Diagrams .....	26
V.	Sound Pressure Levels .....	30
1.	Main MDC.....	30
2.	Sub MDC .....	32

# I. Multiport Distribution Controller (MDC) Basic Information

## 1. Specifications

Table 1 - Data Table

Model		40VMD006M--3			
Number of ports		6			
Power source		208V/230V-1Ph-60Hz			
Power input	KW	0.08			
MCA	A	0.73			
External finish		Hot-dip galvanized steel plate with powder coating			
Connectable outdoor unit		38VMR – Heat Recovery			
Connectable sub-MDC unit		40VMD006S--3			
Maximum connected capacity		324,000Btu/h			
Capacity / Port	KBtu/h	< 54			
External dimension HxWxD		in. 12-3/4 x 37 x 22-5/8			
Refrigerant Piping	Connectable outdoor unit	Capacity (KBtu/h)	To outdoor unit		
			High pressure pipe	Low pressure pipe	
		072K in. O.D	5/8 Brazed	3/4 Brazed	
		096K in. O.D	3/4 Brazed	7/8 Brazed	
		120K in. O.D	3/4 Brazed	1-1/8 Brazed	
		144~192K in. O.D	7/8 Brazed	1-1/8 Brazed	
		216K in. O.D	1-1/8 Brazed	1-1/8 Brazed	
	240K in. O.D	1-1/8 Brazed	1-3/8 Brazed		
	Connectable indoor unit	Capacity (KBtu/h)	To indoor unit		
			Liquid pipe	Gas pipe	
		05K to 15K in. O.D	1/4 Brazed	1/2 Brazed	
		18K to 54K in. O.D	3/8 Brazed	5/8 Brazed	
	Connectable Sub MDC	Capacity (KBtu/h)	To Sub MDC unit		
			High pressure pipe	Liquid pipe	Low pressure pipe
		to 72K in. O.D	5/8 Brazed	3/8 Brazed	3/4 Brazed
		73K to108K in. O.D	3/4 Brazed	3/8 Brazed	7/8 Brazed
		109K to 126K in. O.D	3/4 Brazed	1/2 Brazed	1-1/8 Brazed
127K to 144K in. O.D	7/8 Brazed	1/2 Brazed	1-1/8 Brazed		
145K to 168K in. O.D	7/8 Brazed	5/8 Brazed	1-1/8 Brazed		
Condensate	in. O.D	1			
Net weight	lbs	132			
Standard accessories		PQ connection wires, Adapter pipes, Flexible drainage pipe			
Note	1. The equipment is for R410A refrigerant. 2. Install this unit in a location where noise emitted by the unit is acceptable. (For use in quiet environments with low background noise, position the MDC controller at least 16.4ft away from any indoor units.) 3. The data presented is based on a specific combination.				

Table 2 - Data Table

Model		40VMD008M--3			
Number of ports		8			
Power source		208V/230V-1Ph-60Hz			
Power input	KW	0.097			
MCA	A	0.89			
External finish		Hot-dip galvanized steel plate with powder coating			
Connectable outdoor unit		38VMR – Heat Recovery			
Connectable sub-MDC unit		40VMD006, 008S--3			
Maximum connected capacity		360,000Btu/h			
Capacity / Port	KBtu/h	<54			
External dimension HxWxD	in.	12-3/4 x 37 x 22-5/8			
Refrigerant Piping	Connectable outdoor unit	Capacity (KBtu/h)	To outdoor unit		
			High pressure pipe	Low pressure pipe	
		072K in. O.D	5/8 Brazed	3/4 Brazed	
		096K in. O.D	3/4 Brazed	7/8 Brazed	
		120K in. O.D	3/4 Brazed	1-1/8 Brazed	
		144~192K in. O.D	7/8 Brazed	1-1/8 Brazed	
		216K in. O.D	1-1/8 Brazed	1-1/8 Brazed	
	240K in. O.D	1-1/8 Brazed	1-3/8 Brazed		
	Connectable indoor unit	Capacity (KBtu/h)	To indoor unit		
			Liquid pipe	Gas pipe	
		05K to 15K in. O.D	1/4 Brazed	1/2 Brazed	
		18K to 54K in. O.D	3/8 Brazed	5/8 Brazed	
	Connectable Sub MDC	Capacity (KBtu/h)	To Sub MDC unit		
			High pressure pipe	Liquid pipe	Low pressure pipe
		to 72K in. O.D	5/8 Brazed	3/8 Brazed	3/4 Brazed
		73K to108K in. O.D	3/4 Brazed	3/8 Brazed	7/8 Brazed
		109K to 126K in. O.D	3/4 Brazed	1/2 Brazed	1-1/8 Brazed
127K to 144K in. O.D		7/8 Brazed	1/2 Brazed	1-1/8 Brazed	
145K to 168K in. O.D	7/8 Brazed	5/8 Brazed	1-1/8 Brazed		
Condensate	in. O.D	1			
Net weight	lbs	137			
Standard accessories		PQ connection wires, Adapter pipes, Flexible drainage pipe			
Note	1. The equipment is for R410A refrigerant. 2. Install this unit in a location where noise emitted by the unit is acceptable. (For use in quiet environments with low background noise, position the MDC controller at least 16.4ft away from any indoor units.) 3. The data presented is based on a specific combination.				

Table 3 - Data Table

Model		40VMD010M--3			
Number of ports		10			
Power source		208V/230V-1Ph-60Hz			
Power input	KW	0.113			
MCA	A	1.05			
External finish		Hot-dip galvanized steel plate with powder coating			
Connectable outdoor unit		38VMR – Heat Recovery			
Connectable sub-MDC unit		40VMD006, 008, 010S--3			
Maximum connected capacity		360,000Btu/h			
Capacity / Port	KBtu/h	<54			
External dimension HxWxD		in. 12-3/4 x 37 x 22-5/8			
Refrigerant Piping	Connectable outdoor unit	Capacity (KBtu/h)	To outdoor unit		
			High pressure pipe	Low pressure pipe	
		072K in. O.D	5/8 Brazed	3/4 Brazed	
		096K in. O.D	3/4 Brazed	7/8 Brazed	
		120K in. O.D	3/4 Brazed	1-1/8 Brazed	
		144~192K in. O.D	7/8 Brazed	1-1/8 Brazed	
		216K in. O.D	1-1/8 Brazed	1-1/8 Brazed	
	240K in. O.D	1-1/8 Brazed	1-3/8 Brazed		
	Connectable indoor unit	Capacity (KBtu/h)	To indoor unit		
			Liquid pipe	Gas pipe	
		05K to 15K in. O.D	1/4 Brazed	1/2 Brazed	
		18K to 54K in. O.D	3/8 Brazed	5/8 Brazed	
	72K to 96K in. O.D	3/8 Brazed	7/8 Brazed		
	Connectable Sub MDC	Capacity (KBtu/h)	To Sub MDC unit		
			High pressure pipe	Liquid pipe	Low pressure pipe
		to 72K in. O.D	5/8 Brazed	3/8 Brazed	3/4 Brazed
		73K to108K in. O.D	3/4 Brazed	3/8 Brazed	7/8 Brazed
		109K to 126K in. O.D	3/4 Brazed	1/2 Brazed	1-1/8 Brazed
127K to 144K in. O.D		7/8 Brazed	1/2 Brazed	1-1/8 Brazed	
145K to 168K in. O.D	7/8 Brazed	5/8 Brazed	1-1/8 Brazed		
Condensate	in. O.D	1			
Net weight	lbs	143			
Standard accessories		PQ connection wires, Adapter pipes, Flexible drainage pipe			
Note	1. The equipment is for R410A refrigerant. 2. Install this unit in a location where noise emitted by the unit is acceptable. (For use in quiet environments with low background noise, position the MDC controller at least 16.4ft away from any indoor units.) 3. The data presented is based on a specific combination.				

Table 4 - Data Table

Model		40VMD016M--3			
Number of ports		16			
Power source		208V/230V-1Ph-60Hz			
Power input	KW	0.163			
MCA	A	1.54			
External finish		Hot-dip galvanized steel plate with powder coating			
Connectable outdoor unit		38VMR-Heat Recovery			
Connectable sub-MDC unit		40VMD006, 008, 010, 016S--3			
Maximum connected capacity		360,000Btu/h			
Capacity / Port	KBtu/h	<54			
External dimension HxWxD	in.	12-3/4 x 46-1/2 x 22-5/8			
Refrigerant Piping	Connectable outdoor unit	Capacity (KBtu/h)	To outdoor unit		
			High pressure pipe	Low pressure pipe	
		072K in. O.D	5/8 Brazed	3/4 Brazed	
		096K in. O.D	3/4 Brazed	7/8 Brazed	
		120K in. O.D	3/4 Brazed	1-1/8 Brazed	
		144~192K in. O.D	7/8 Brazed	1-1/8 Brazed	
		216K in. O.D	1-1/8 Brazed	1-1/8 Brazed	
	240K in. O.D	1-1/8 Brazed	1-3/8 Brazed		
	Connectable indoor unit	Capacity (KBtu/h)	To indoor unit		
			Liquid pipe	Gas pipe	
		05K to 15K in. O.D	1/4 Brazed	1/2 Brazed	
		18K to 54K in. O.D	3/8 Brazed	5/8 Brazed	
	Connectable Sub MDC	Capacity (KBtu/h)	To Sub MDC unit		
			High pressure pipe	Liquid pipe	Low pressure pipe
		to 72K in. O.D	5/8 Brazed	3/8 Brazed	3/4 Brazed
		73K to108K in. O.D	3/4 Brazed	3/8 Brazed	7/8 Brazed
		109K to 126K in. O.D	3/4 Brazed	1/2 Brazed	1-1/8 Brazed
127K to 144K in. O.D	7/8 Brazed	1/2 Brazed	1-1/8 Brazed		
145K to 168K in. O.D	7/8 Brazed	5/8 Brazed	1-1/8 Brazed		
Condensate	in. O.D	1			
Net weight	lbs	190			
Standard accessories		PQ connection wires, Adapter pipes, Flexible drainage pipe			
Note	1. The equipment is for R410A refrigerant. 2. Install this unit in a location where noise emitted by the unit is acceptable. (For use in quiet environments with low background noise, position the MDC controller at least 16.4ft away from any indoor units.) 3. The data presented is based on a specific combination.				

Table 5 - Data Table

Model		40VMD016ML-3			
Number of ports		16			
Power source		208V/230V-1Ph-60Hz			
Power input	KW	0.163			
MCA	A	1.54			
External finish		Hot-dip galvanized steel plate with powder coating			
Connectable outdoor unit		38VMR – Heat Recovery			
Connectable sub-MDC unit		40VMD006, 008, 010, 016S--3			
Maximum connected capacity		504,000Btu/h			
Capacity / Port	KBtu/h	<54			
External dimension HxWxD		in. 12-3/4 x 46-1/2 x 22-5/8			
Refrigerant Piping	Connectable outdoor unit	Capacity (KBtu/h)	To outdoor unit		
			High pressure pipe	Low pressure pipe	
		072K in. O.D	5/8 Brazed	3/4 Brazed	
		096K in. O.D	3/4 Brazed	7/8 Brazed	
		120K in. O.D	3/4 Brazed	1-1/8 Brazed	
		144~192K in. O.D	7/8 Brazed	1-1/8 Brazed	
		216K in. O.D	1-1/8 Brazed	1-1/8 Brazed	
		240~288K in. O.D	1-1/8 Brazed	1-3/8 Brazed	
	312~336K in. O.D	1-1/8 Brazed	1-5/8 Brazed		
	Connectable indoor unit	Capacity (KBtu/h)	To indoor unit		
			Liquid pipe	Gas pipe	
		05K to 15K in. O.D	1/4 Brazed	1/2 Brazed	
		18K to 54K in. O.D	3/8 Brazed	5/8 Brazed	
	Connectable Sub MDC	Capacity (KBtu/h)	To Sub MDC unit		
			High pressure pipe	Liquid pipe	Low pressure pipe
		to 72K in. O.D	5/8 Brazed	3/8 Brazed	3/4 Brazed
		73K to108K in. O.D	3/4 Brazed	3/8 Brazed	7/8 Brazed
		109K to 126K in. O.D	3/4 Brazed	1/2 Brazed	1-1/8 Brazed
		127K to 144K in. O.D	7/8 Brazed	1/2 Brazed	1-1/8 Brazed
	145K to 168K in. O.D	7/8 Brazed	5/8 Brazed	1-1/8 Brazed	
Condensate	in. O.D	1			
Net weight	lbs	196			
Standard accessories		PQ connection wires, Adapter pipes, Flexible drainage pipe			
Note	1. The equipment is for R410A refrigerant. 2. Install this unit in a location where noise emitted by the unit is acceptable. (For use in quiet environments with low background noise, position the MDC controller at least 16.4ft away from any indoor units.) 3. The data presented is based on a specific combination.				

Table 6 - Data Table

Model		40VMD006S--3			
Number of ports		6			
Power source		208V/230V-1Ph-60Hz			
Power input	KW	0.075			
MCA	A	0.69			
External finish		Hot-dip galvanized steel plate with powder coating			
Connectable outdoor unit		38VMA096-336RDS(L) model			
Connectable Main MDC Unit		40VMD006, 008, 010, 016M--3, 40VMD016ML-3			
Maximum connected capacity		126,000Btu/h*			
Capacity / Port	KBtu/h	<54			
External dimension HxWxD	in.	12-3/4 x 37 x 22-5/8			
Refrigerant Piping	Connectable indoor unit	Capacity (KBtu/h)			
		To indoor unit			
		Liquid pipe		Gas pipe	
		05K to 15K in. O.D	1/4 Brazed	1/2 Brazed	
	18K to 54K in. O.D		3/8 Brazed	5/8 Brazed	
	72K to 96K in. O.D		3/8 Brazed	7/8 Brazed	
	Total indoor unit capacity in sub MDC*	Capacity (KBtu/h)			
		To Main MDC unit			
		High pressure pipe		Liquid pipe	Low pressure pipe
		to 72K in. O.D	5/8 Brazed	3/8 Brazed	3/4 Brazed
		73K to 108K in. O.D	3/4 Brazed	3/8 Brazed	7/8 Brazed
		109K to 126K in. O.D	3/4 Brazed	1/2 Brazed	1-1/8 Brazed
127K to 144K in. O.D		7/8 Brazed	1/2 Brazed	1-1/8 Brazed	
145K to 168K in. O.D		7/8 Brazed	5/8 Brazed	1-1/8 Brazed	
Condensate	in. O.D	1			
Net weight	lbs	126			
Standard accessories		PQ connection wires, Adapter pipes, Flexible drainage pipe			
Note	1. The equipment is for R410A refrigerant. 2. Install this unit in a location where noise emitted by the unit is acceptable. (For use in quiet environments with low background noise, position the MDC controller at least 16.4ft away from any indoor units.) 3. The data presented is based on a specific combination.				

\* If two sub MDC are used, the total capacity is the summation of the two, which must not exceed 168,000Btu/h.



Table 7 - Data Table

Model		40VMD008S--3			
Number of ports		8			
Power source		208V/230V-1Ph-60Hz			
Power input MCA	KW	0.092			
	A	0.85			
External finish		Hot-dip galvanized steel plate with powder coating			
Connectable outdoor unit		38VMR – Heat Recovery			
Connectable Main MDC Unit		40VMD008, 010, 016M--3, 40VMD016ML-3			
Maximum connected capacity		126,000Btu/h*			
Capacity / Port	KBtu/h	<54			
External dimension HxWxD		in. 12-3/4 x 37 x 22-5/8			
Refrigerant Piping	Connectable indoor unit	Capacity (KBtu/h)			
		To indoor unit			
			Liquid pipe	Gas pipe	
		05K to 15K in. O.D	1/4 Brazed	1/2 Brazed	
	18K to 54K in. O.D	3/8 Brazed	5/8 Brazed		
	72K to 96K in. O.D	3/8 Brazed	7/8 Brazed		
	Total indoor unit capacity in sub MDC*	Capacity (KBtu/h)			
		To Main MDC unit			
			High pressure pipe	Liquid pipe	Low pressure pipe
		to 72K in. O.D	5/8 Brazed	3/8 Brazed	3/4 Brazed
		73K to 108K in. O.D	3/4 Brazed	3/8 Brazed	7/8 Brazed
		109K to 126K in. O.D	3/4 Brazed	1/2 Brazed	1-1/8 Brazed
127K to 144K in. O.D	7/8 Brazed	1/2 Brazed	1-1/8 Brazed		
145K to 168K in. O.D	7/8 Brazed	5/8 Brazed	1-1/8 Brazed		
Condensate		in. O.D 1			
Net weight		lbs 130			
Standard accessories		PQ connection wires, Adapter pipes, Flexible drainage pipe			
Note	1. The equipment is for R410A refrigerant. 2. Install this unit in a location where noise emitted by the unit is acceptable. (For use in quiet environments with low background noise, position the MDC controller at least 16.4ft away from any indoor units.) 3. The data presented is based on a specific combination.				

\* If two sub MDC are used, the total capacity is the summation of the two, which must not exceed 168,000Btu/h.

Table 8 - Data Table

Model		40VMD010S--3			
Number of ports		10			
Power source		208V/230V-1Ph-60Hz			
Power input	KW	0.109			
MCA	A	1.01			
External finish		Hot-dip galvanized steel plate with powder coating			
Connectable outdoor unit		38VMR – Heat Recovery			
Connectable main MDC unit		40VMD010, 16M--3, 40VMD016ML-3			
Maximum connected capacity		126,000Btu/h*			
Capacity / Port	KBtu/h	<54			
External dimension HxWxD		in. 12-3/4 x 37 x 22-5/8			
Refrigerant Piping	Connectable indoor unit	Capacity (KBtu/h)	To indoor unit		
			Liquid pipe	Gas pipe	
		05K to 15K in. O.D	1/4 Brazed	1/2 Brazed	
		18K to 54K in. O.D	3/8 Brazed	5/8 Brazed	
		72K to 96K in. O.D	3/8 Brazed	7/8 Brazed	
	Total indoor unit capacity in sub MDC *	Capacity (KBtu/h)	To Main MDC unit		
			High pressure pipe	Liquid pipe	Low pressure pipe
		to 72K in. O.D	5/8 Brazed	3/8 Brazed	3/4 Brazed
		73K to 108K in. O.D	3/4 Brazed	3/8 Brazed	7/8 Brazed
		109K to 126K in. O.D	3/4 Brazed	1/2 Brazed	1-1/8 Brazed
		127K to 144K in. O.D	7/8 Brazed	1/2 Brazed	1-1/8 Brazed
		145K to 168K in. O.D	7/8 Brazed	5/8 Brazed	1-1/8 Brazed
Condensate		in. O.D	1		
Net weight		lbs	137		
Standard accessories		PQ connection wires, Adapter pipes, Flexible drainage pipe			
Note	1. The equipment is for R410A refrigerant. 2. Install this unit in a location where noise emitted by the unit is acceptable. (For use in quiet environments with low background noise, position the MDC controller at least 16.4ft away from any indoor units.) 3. The data presented is based on a specific combination.				

\*If two sub MDC are used, the total capacity is the summation of the two, which must not exceed 168,000 Btu/h.

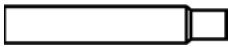





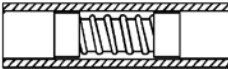



Table 9 - Data Table

Model		40VMD016S--3			
Number of ports		16			
Power source		208V/230V-1Ph-60Hz			
Power input	KW	0.159			
MCA	A	1.49			
External finish		Hot-dip galvanized steel plate with powder coating			
Connectable outdoor unit		38VMR – Heat Recovery			
Connectable main MDC unit		40VMD016M--3, 40VMD016ML-3			
Maximum connected capacity		126,000Btu/h*			
Capacity / Port	KBtu/h	<54			
External dimension HxWxD		in. 12-3/4 x 46-1/2 x 22-5/8			
Refrigerant Piping	Connectable indoor unit	Capacity (KBtu/h)	To indoor unit		
			Liquid pipe	Gas pipe	
		5K to 15K in. O.D	1/4 Brazed	1/2 Brazed	
		18K to 54K in. O.D	3/8 Brazed	5/8 Brazed	
		72K to 96K in. O.D	3/8 Brazed	7/8 Brazed	
	Total indoor unit capacity in sub MDC *1	Capacity (KBtu/h)	To Main MDC unit		
			High pressure pipe	Liquid pipe	Low pressure pipe
		to 72K in. O.D	5/8 Brazed	3/8 Brazed	3/4 Brazed
		73K to 108K in. O.D	3/4 Brazed	3/8 Brazed	7/8 Brazed
		109K to 126K in. O.D	3/4 Brazed	1/2 Brazed	1-1/8 Brazed
127K to 144K in. O.D		7/8 Brazed	1/2 Brazed	1-1/8 Brazed	
	145K to 168K in. O.D	7/8 Brazed	5/8 Brazed	1-1/8 Brazed	
Condensate		in. O.D 1			
Net weight		lbs 183			
Standard accessories		PQ connection wires, Adapter pipes, Flexible drainage pipe			
Note	1. The equipment is for R410A refrigerant. 2. Install this unit in a location where noise emitted by the unit is acceptable. (For use in quiet environments with low background noise, position the MDC controller at least 16.4ft away from any indoor units.) 3. The data presented is based on a specific combination.				

1. \*1 - If two sub MDC are used, the total capacity is the summation of them which must not exceed 168,000Btu/h.

## 2. Accessories

Table 10 - Table of Accessories

Name	Shape	Quantity	Function
Adapter pipe for liquid line		Same as MDC ports	Use for indoor unit (capacity 05~15Btu/h)
Adapter pipe for gas line		Same as MDC ports	
Adapter pipe for liquid line		2	Use for the connection between the main MDC and 1 sub MDC unit (available only with the sub MDC)
Adapter pipe for low pressure line		2	
Adapter pipe for high pressure line		2	
Clamp		2	To fasten the connector between flexible condensate pipe and MDC condensate
Condensate connection		2	Reducer for smaller pipe diameter (only for size 018 unit)
PQE connection wire		No. of Ports + 3	Connects outdoor unit, indoor unit, and MDC
Adapter pipe (for high pressure line)		1	Only for 40VMD016ML-3, used for connection to 072-240 size outdoor unit
Adapter pipe (for low pressure line)		1	

## II. Dimensions

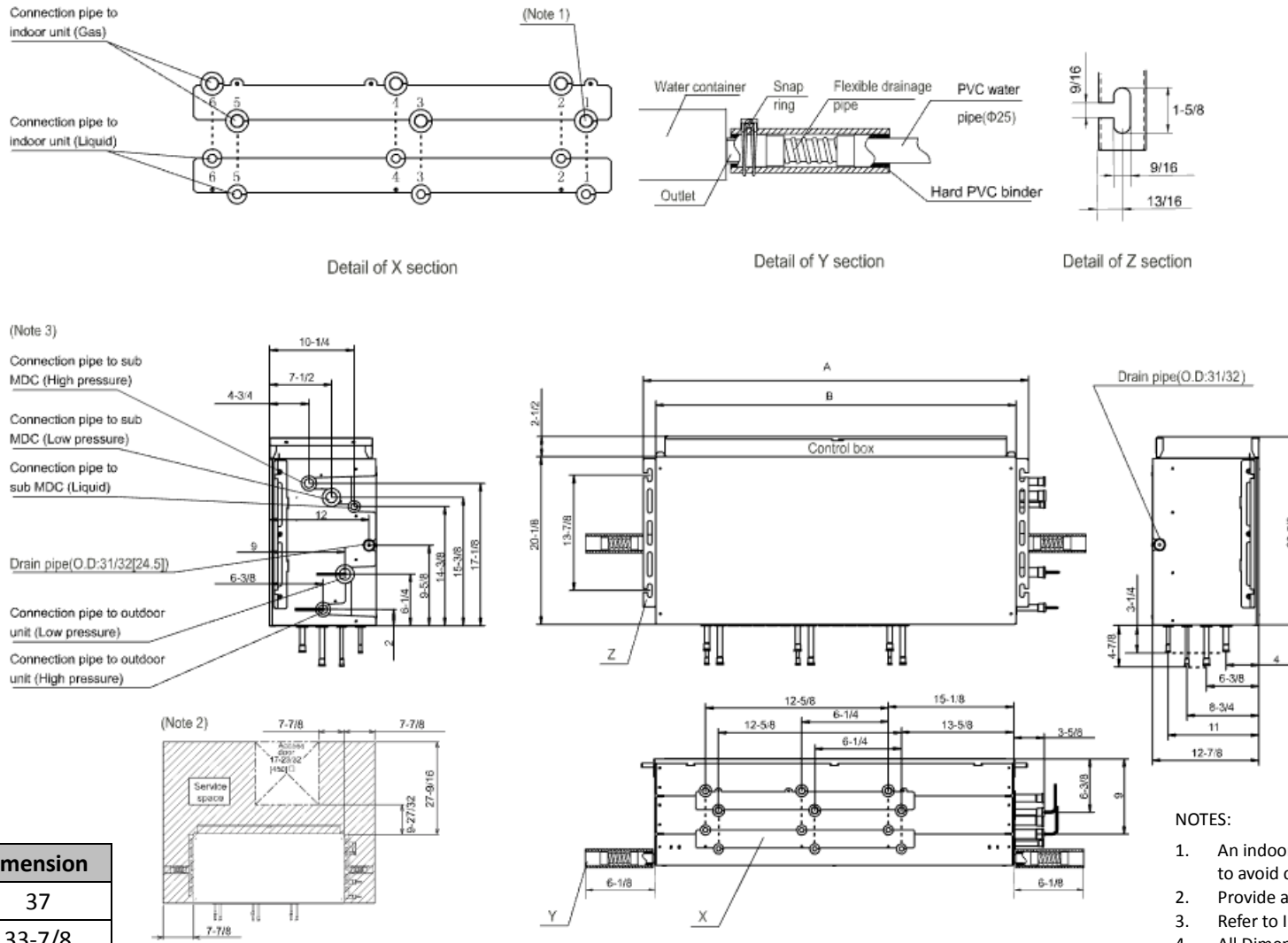

Symbol	Dimension
A	37
B	33-7/8

Figure 1 - 40VMD006M--3

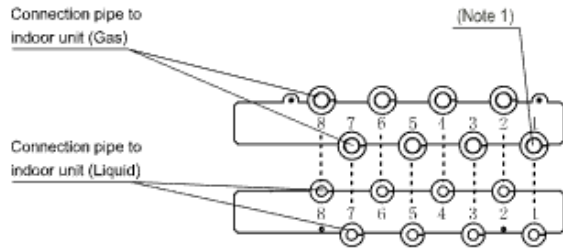

Detail of X section

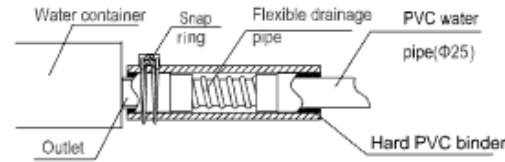

Detail of Y section

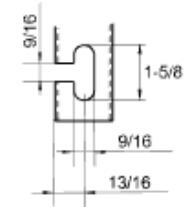

Detail of Z section

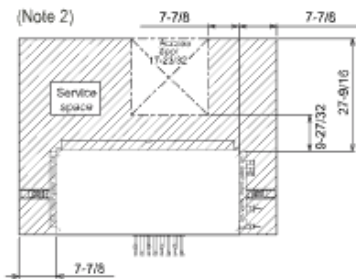
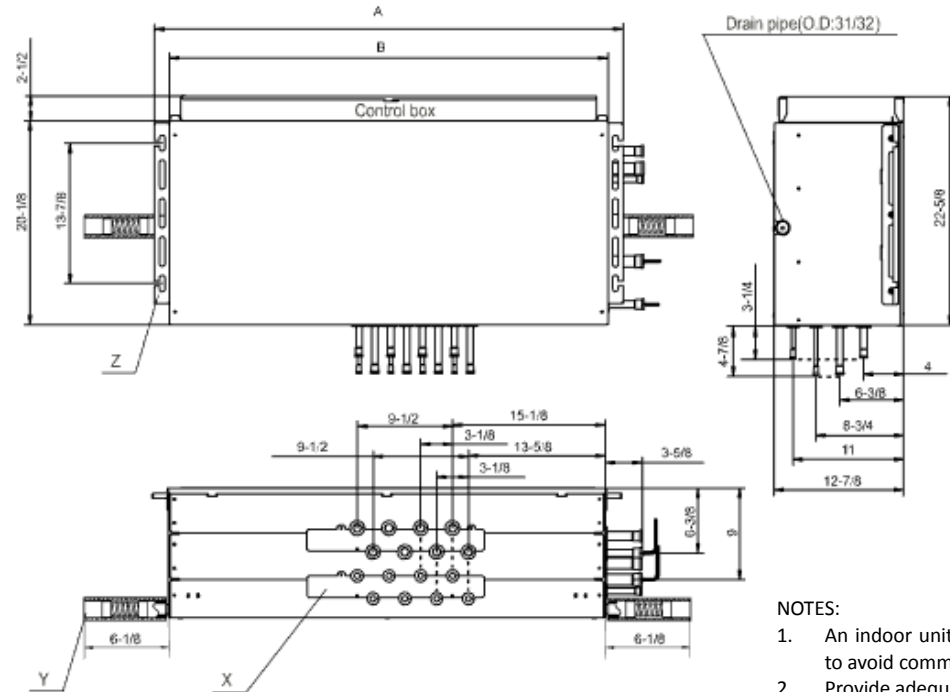
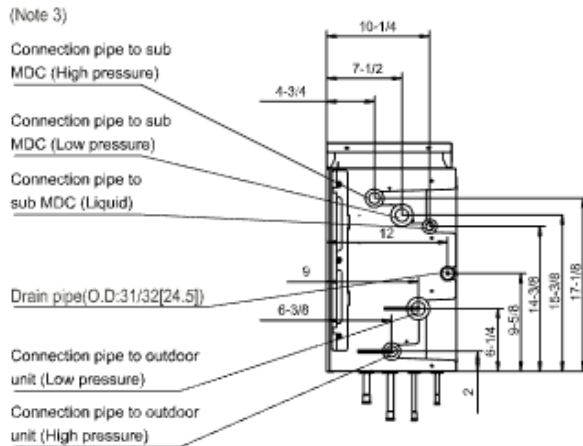

Symbol	Dimension
A	37
B	33-7/8

- NOTES:
1. An indoor unit must be connected to port #1 to avoid communication error.
  2. Provide adequate service clearance.
  3. Refer to Installation Manual for piping sizes.
  4. All Dimensions are shown in inches.

Figure 2 - 40VMD008M—3

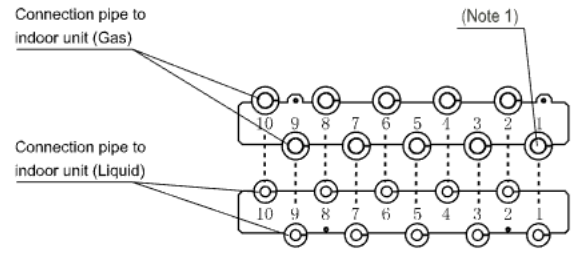

Detail of X section

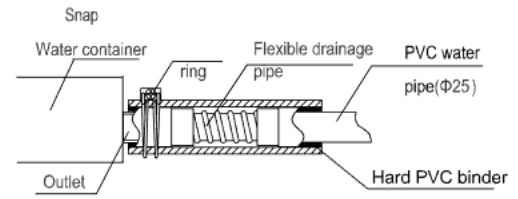

Detail of Y section

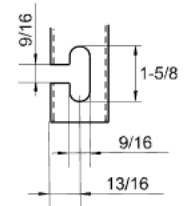

Detail of Z section

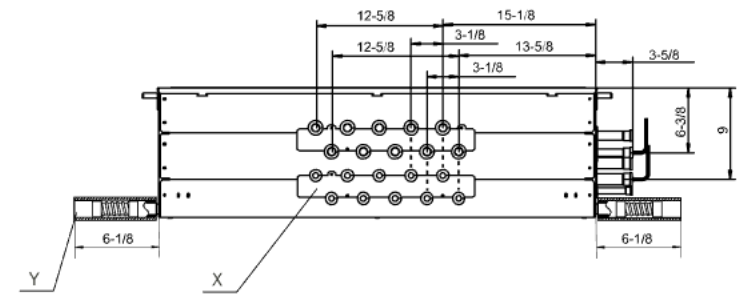
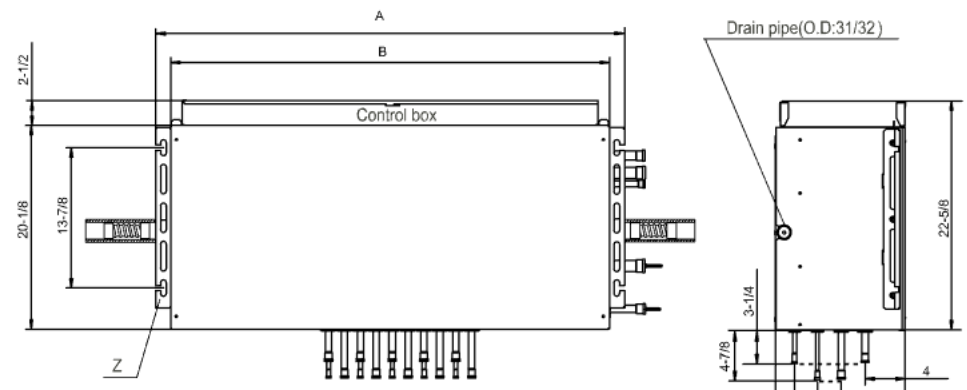
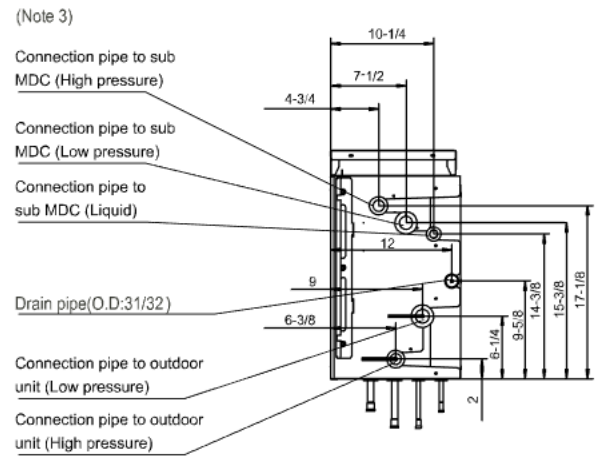

NOTES:

1. An indoor unit must be connected to port #1 to avoid communication error.
2. Provide adequate service clearance.
3. Refer to Installation Manual for piping sizes.
4. All Dimensions are shown in inches.

Symbol	Dimension
A	37
B	33-7/8

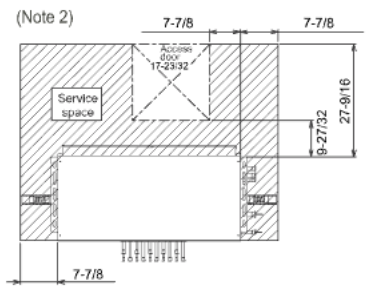
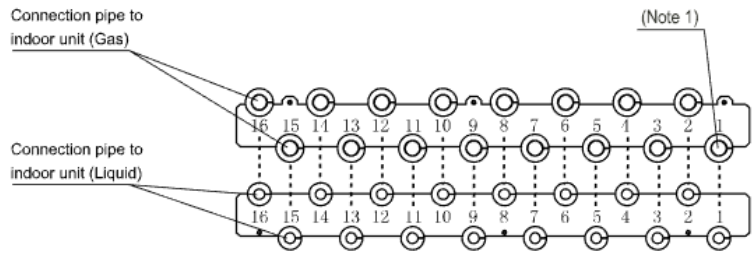
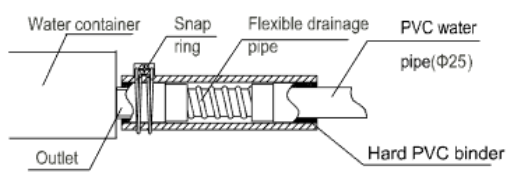

Figure 3 - 40VMD010M--3



Detail of X section



Detail of Y section

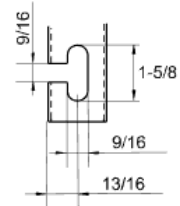

Detail of Z section

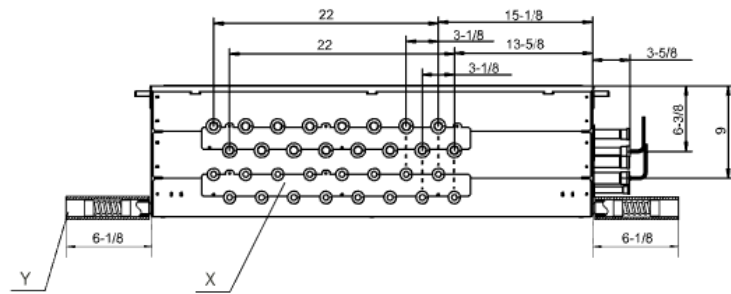
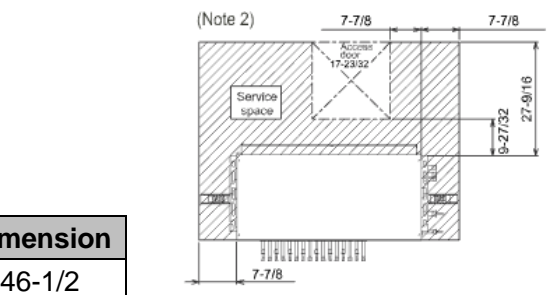
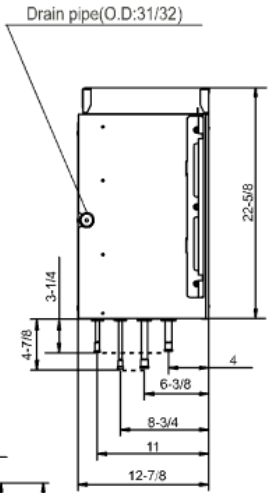
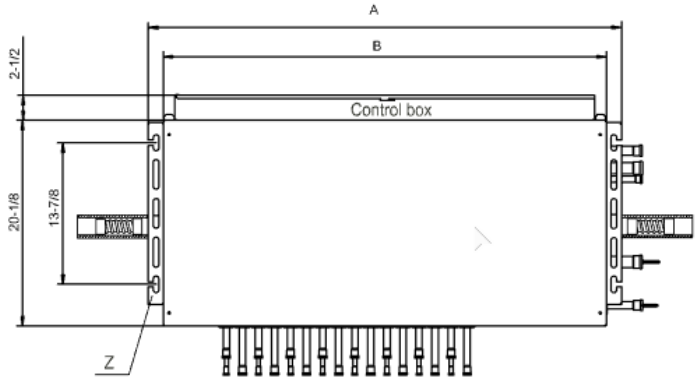
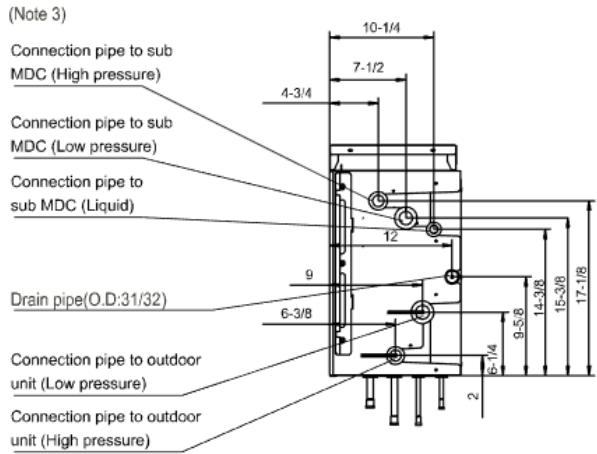

Symbol	Dimension
A	46-1/2
B	43-1/4

Figure 4 - 40VMD016M--3

- NOTES:
1. An indoor unit must be connected to port #1 to avoid communication error.
  2. Provide adequate service clearance.
  3. Refer to Installation Manual for piping sizes.
  4. All Dimensions are shown in inches.



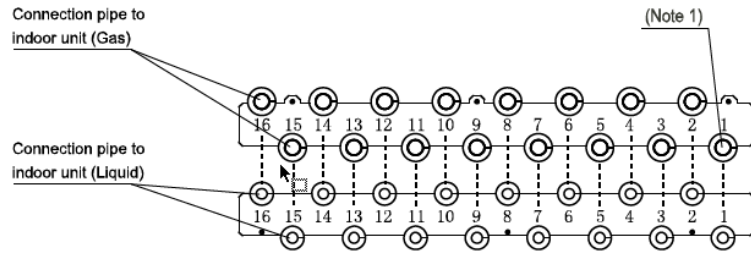

Detail of X section

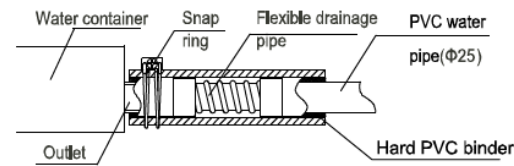

Detail of Y section

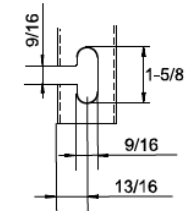

Detail of Z section

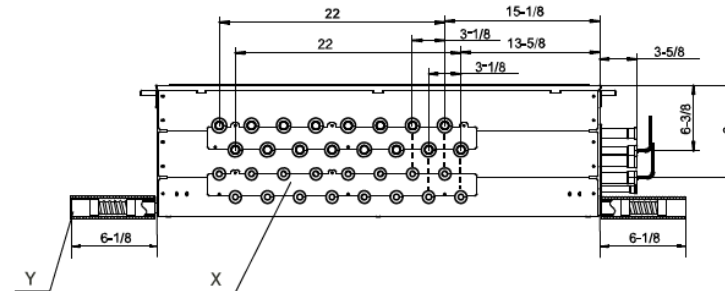
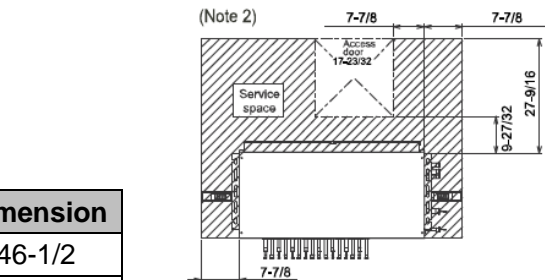
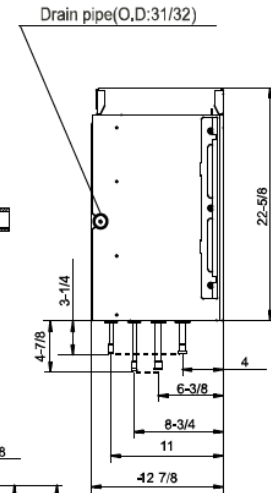
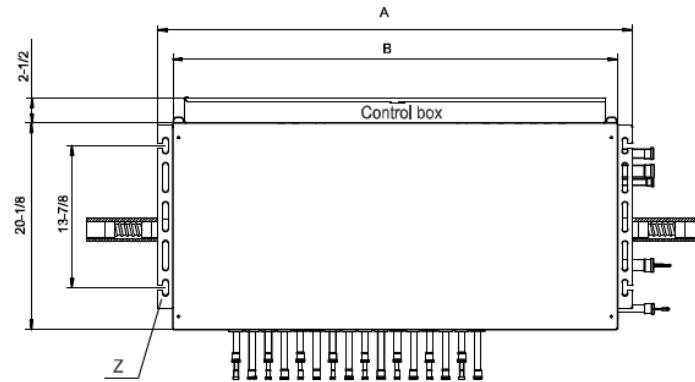
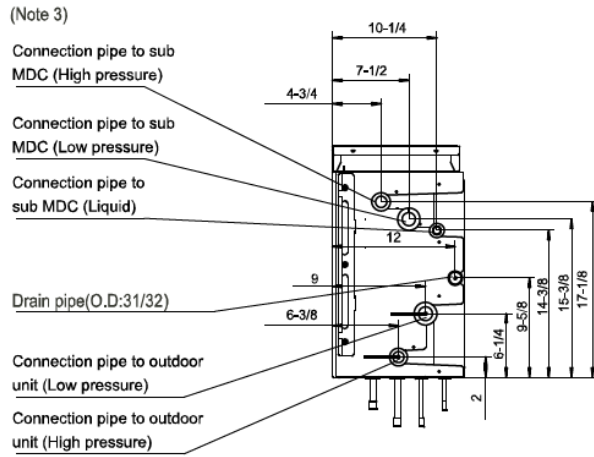

Symbol	Dimension
A	46-1/2
B	43-1/4

Figure 5 - 40VMD016ML-3

NOTES:

1. An indoor unit must be connected to port #1 to avoid communication error.
2. Provide adequate service clearance.
3. Refer to Installation Manual for piping sizes.
4. All Dimensions are shown in inches.

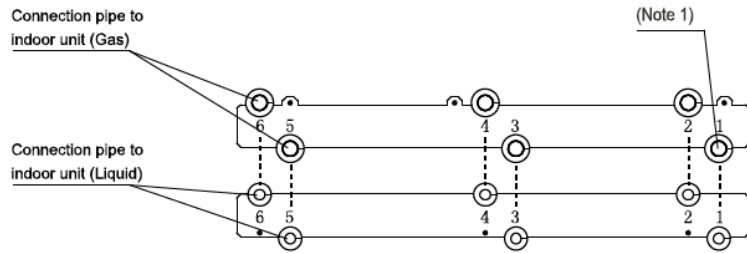

(Note 1)

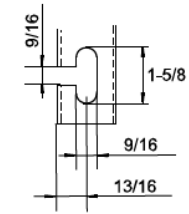
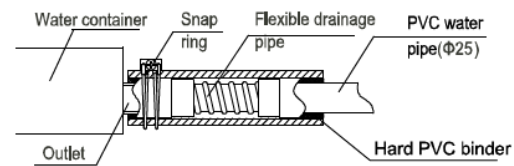

Detail of X section

Detail of Y section

Detail of Z section

(Note 3)

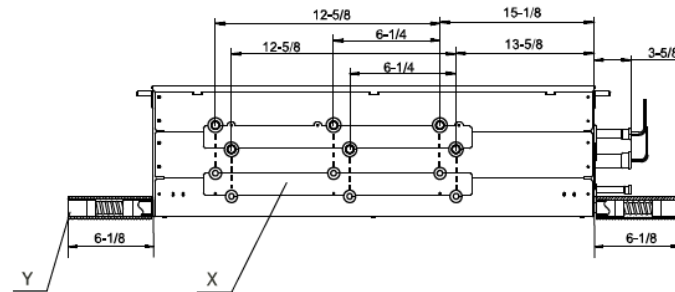
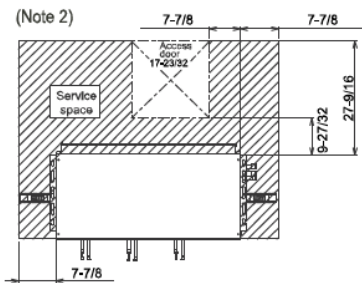
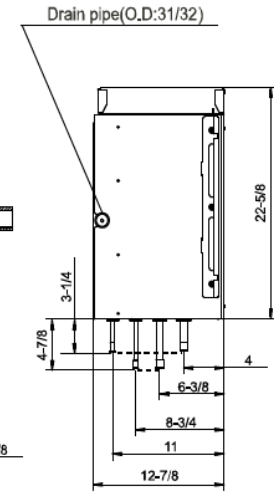
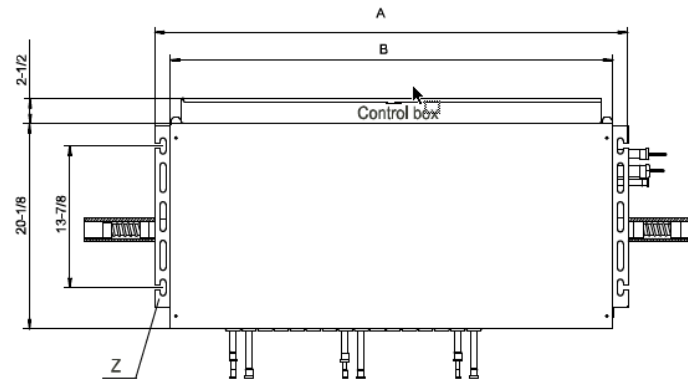
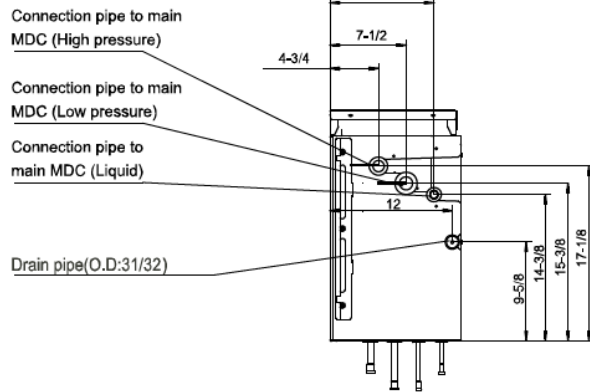

Symbol	Dimension
A	37
B	33-7/8

Figure 6 - 40VMD006S--3

NOTES:

1. An indoor unit must be connected to port #1 to avoid communication error.
2. Provide adequate service clearance.
3. Refer to Installation Manual for piping sizes.
4. All Dimensions are shown in inches.

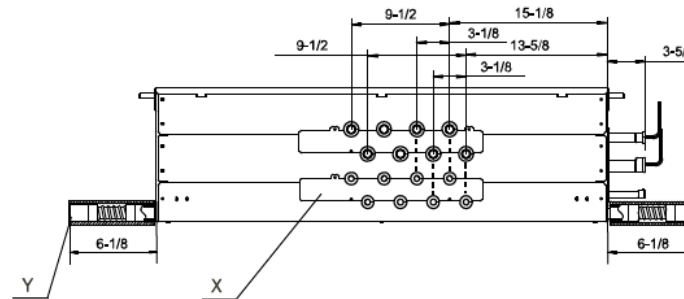
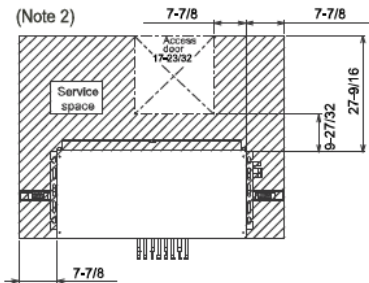
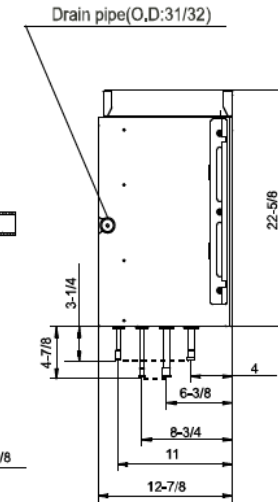
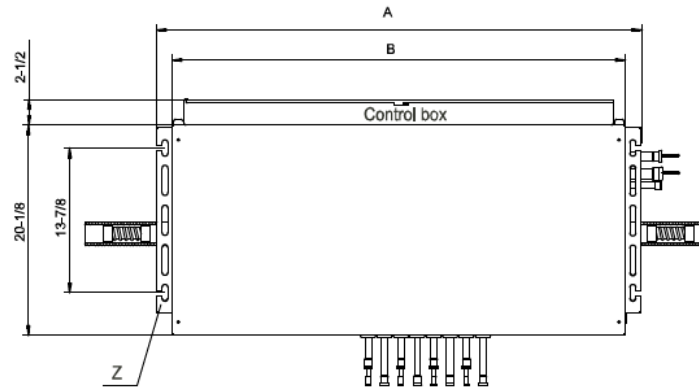
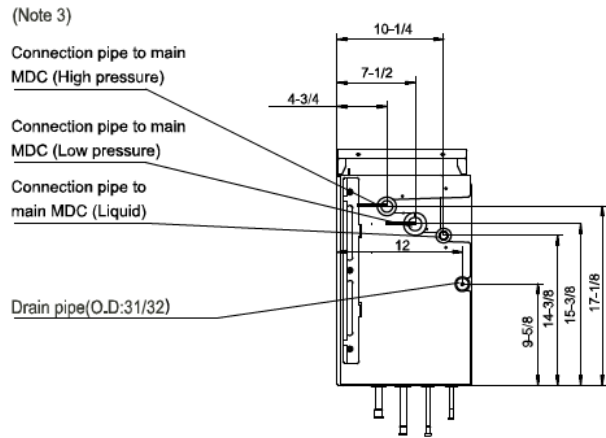
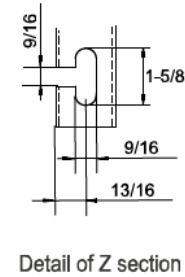
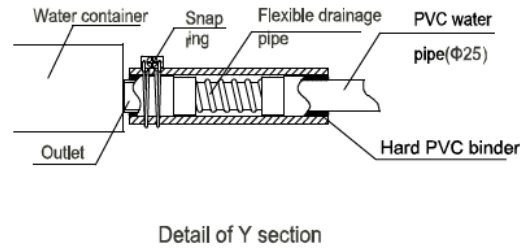
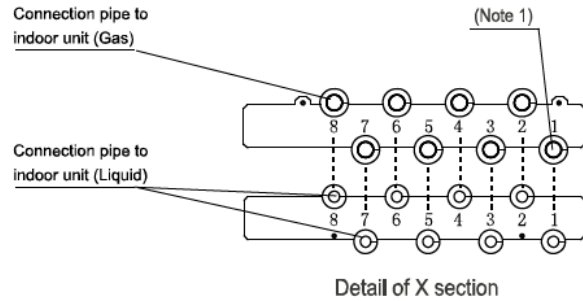

Symbol	Dimension
A	37
B	33-7/8

Figure 7 - 40VMD008S--3

- NOTES:
1. An indoor unit must be connected to port #1 to avoid communication error.
  2. Provide adequate service clearance.
  3. Refer to Installation Manual for piping sizes.
  4. All Dimensions are shown in inches.

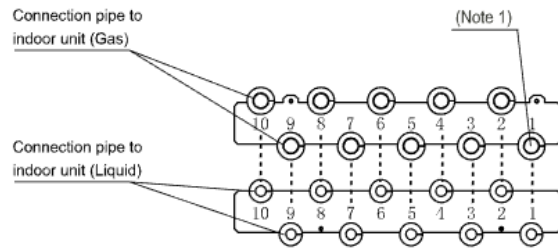

Detail of X section

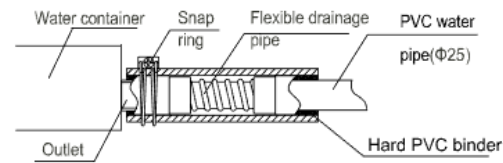

Detail of Y section

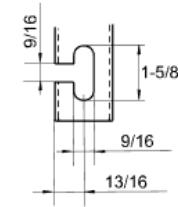

Detail of Z section

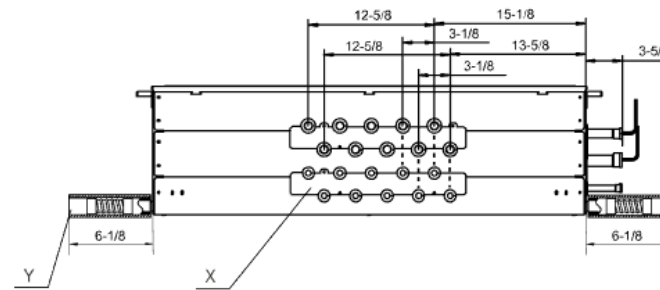
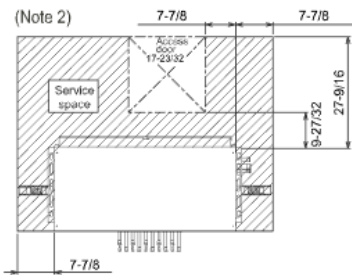
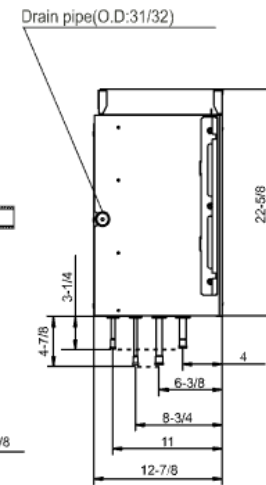
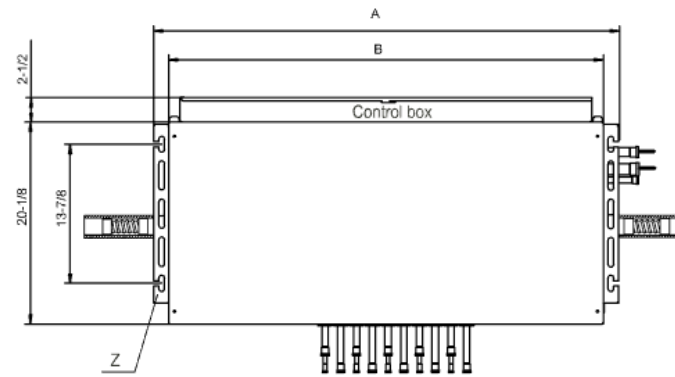
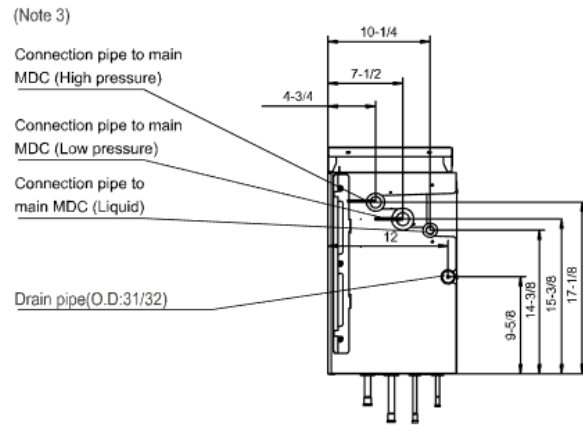

NOTES:

1. An indoor unit must be connected to port #1 to avoid communication error.
2. Provide adequate service clearance.
3. Refer to Installation Manual for piping sizes.
4. All Dimensions are shown in inches.

Symbol	Dimension
A	37
B	33-7/8

Figure 8 - 40VMD010S--3

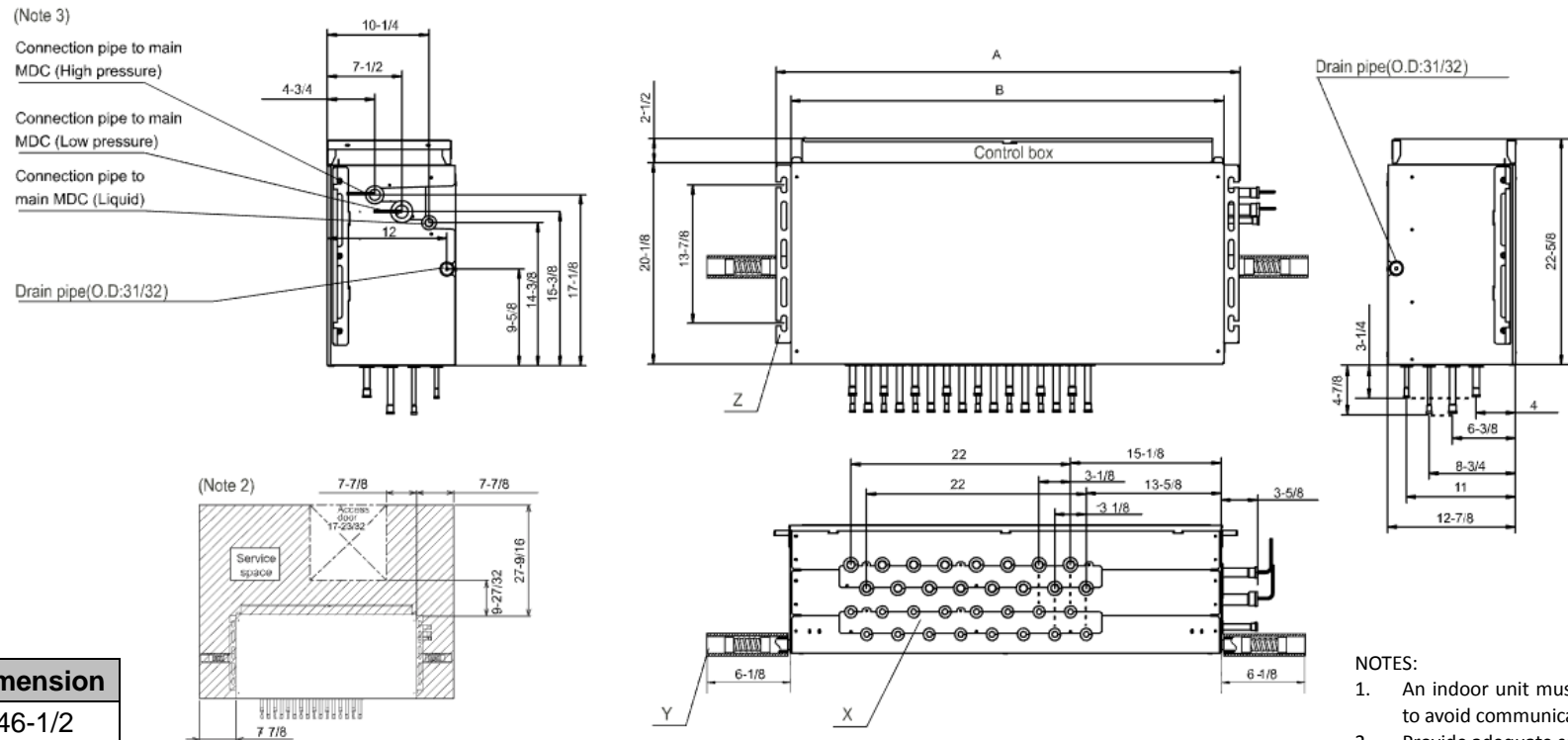
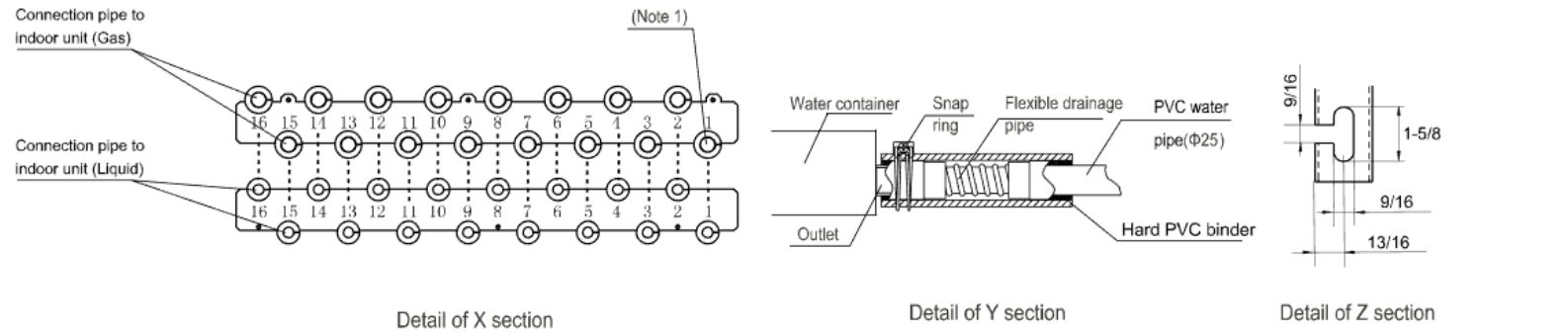

Symbol	Dimension
A	46-1/2
B	43-1/4

Figure 9 - 40VMD016S--3

NOTES:

1. An indoor unit must be connected to port #1 to avoid communication error.
2. Provide adequate service clearance.
3. Refer to Installation Manual for piping sizes.
4. All Dimensions are shown in inches.

### III. Wiring Diagrams

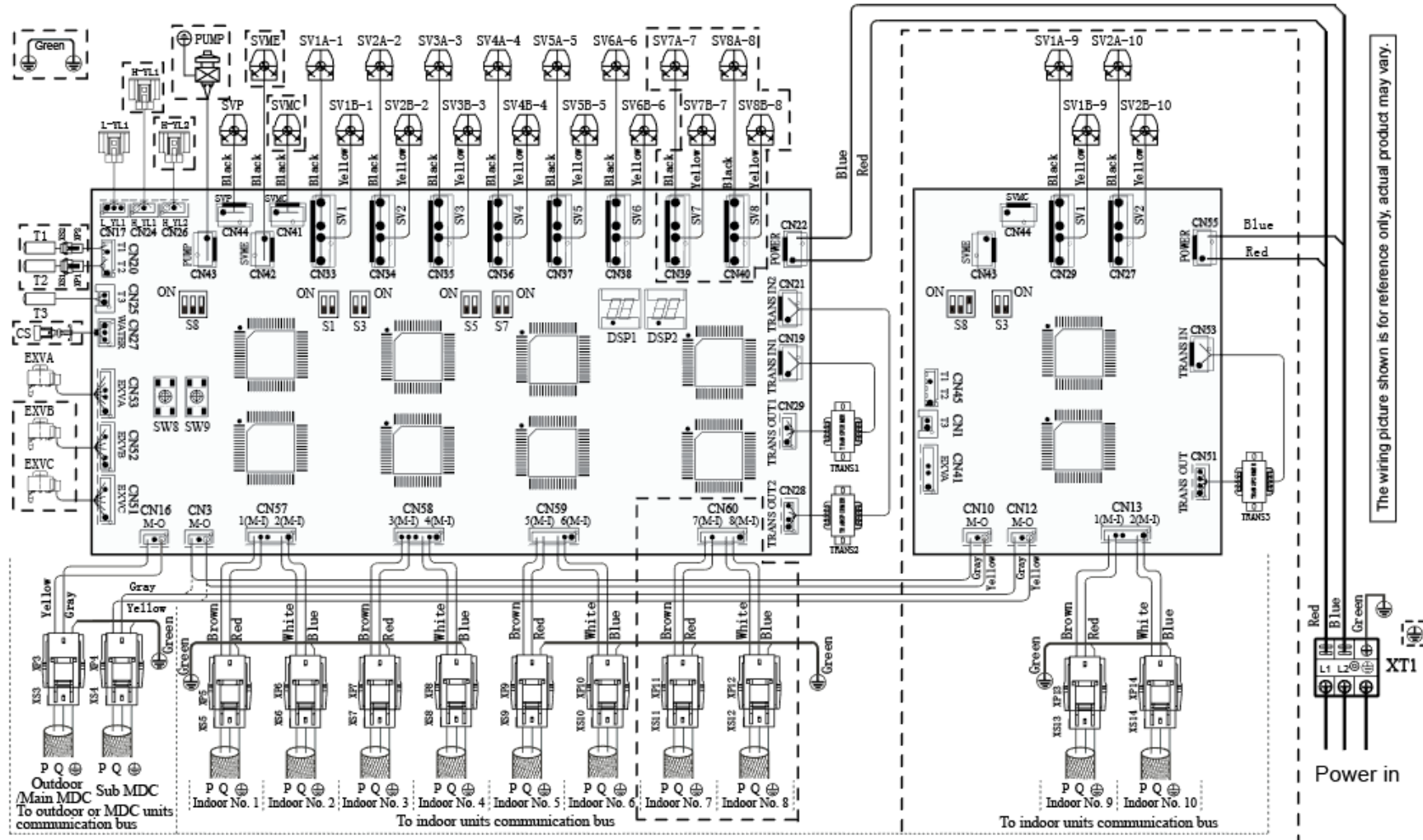

Figure 10 - 40VMD006, 008, 010M(S)--3

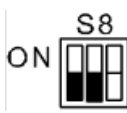

Table 11 - DSP1 and DSP2 display content

S E0	Comm. Error with outdoor unit
S E1	T1 temperature sensor error
S E2	T2 temperature sensor error
S E3	T3 temperature sensor error
S E4	High pressure sensor error
S E5	Intermediate pressure sensor error
S E6	Low pressure sensor error
S P1	High pressure protection
S EP	Float switch failure
SC ER	Commissioning test failure
no ID	No indoor unit under Indoor No. 1
no AD	Faulty address for MDC
CS x	Indoor capacity overload under Indoor No. y (y=x 1)

Table 12 - Legend

Code	Name
XT1	Terminal block
XS1~XS20	Plug
XP1~XP20	Jack
H-YL1	High pressure sensor
H-YL2	Intermediate pressure sensor
L-YL1	Low pressure sensor
T1~T3	Temperature sensor
SV#A-*, SV#B-*, SVP, SVMC, SVME	Soilenoid valve
EXVA~EXVC	Electronic expansion valve
TRANS1~ TRANS4	Transformer
PUMP	Pump motor
CS	Float switch

Table 13 – Main control panel dial code

0/1 definition of each dial code switch	
	<ul style="list-style-type: none"> <li>• 0 means the primary MDC board</li> <li>• 0 means the secondary MDC board (the same MDC control box)</li> </ul>
	<ul style="list-style-type: none"> <li>• 00 means the main MDC control box</li> <li>• 01, 10 means the sub MDC control box</li> </ul>
	<p>1-1-1 means clearing away addresses for all the indoor units under the board (The DSP displays CL ER)</p> <p>CAUTION: After clearing away addresses, the dial code needs to be reset to the previous position.</p>

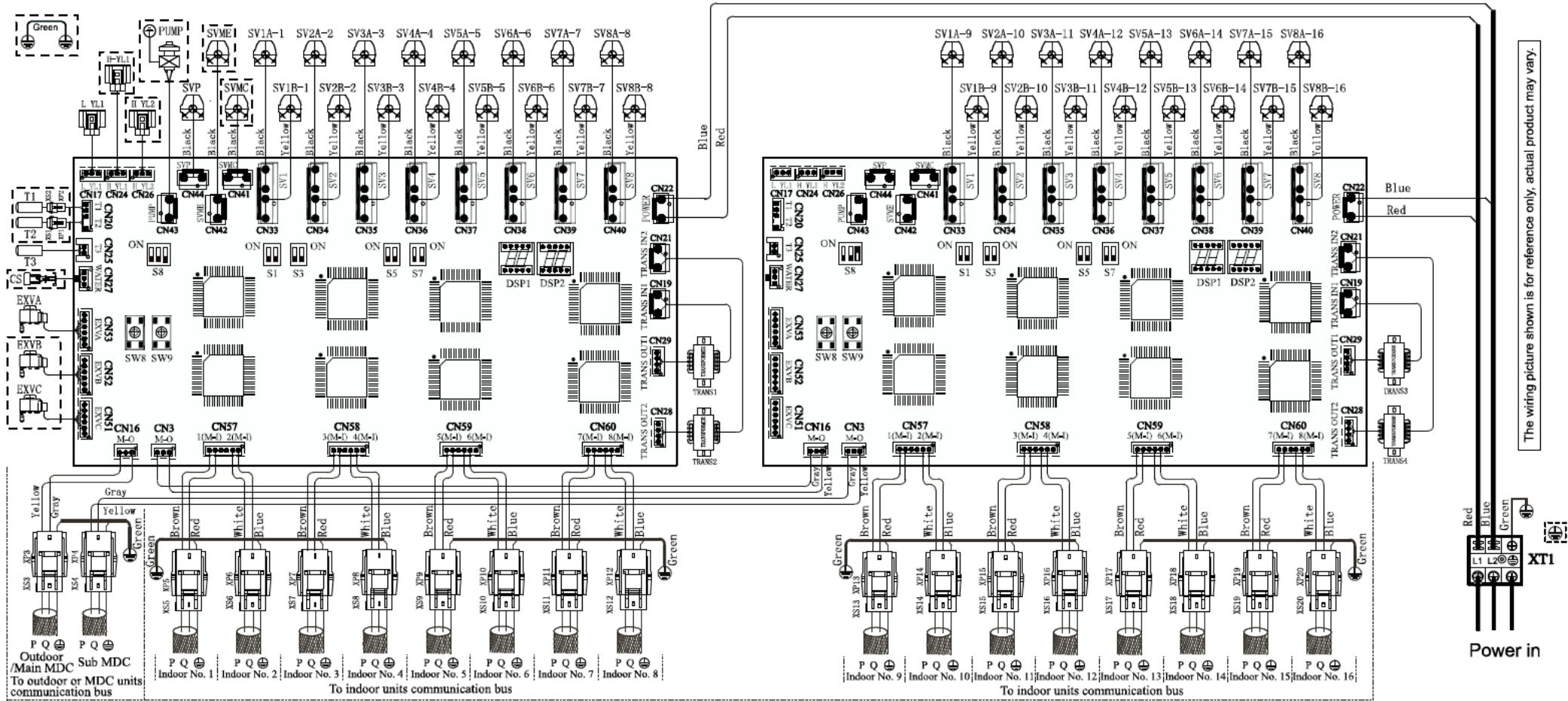

Figure 11 – 40VMD016M, ML, S







Table 14 - DSP1 and DSP2 display content

S E0	Comm. Error with outdoor unit
S E1	T1 temperature sensor error
S E2	T2 temperature sensor error
S E3	T3 temperature sensor error
S E4	High pressure sensor error
S E5	Intermediate pressure sensor error
S E6	Low pressure sensor error
S P1	High pressure protection
S EP	Float switch failure
SC ER	Commissioning test failure
no ID	No indoor unit under Indoor No. 1
no AD	Faulty address for MDC
CS x	Indoor capacity overload under Indoor No. y (y=x 1)

Table 15 - Legend

Code	Name
XT1	Terminal block
XS1~XS20	Plug
XP1~XP20	Jack
H-YL1	High pressure sensor
H-YL2	Intermediate pressure sensor
L-YL1	Low pressure sensor
T1~T3	Temperature sensor
SV#A-*, SV#B-*, SVP, SVMC, SVME	Soilenoid valve
EXVA~EXVC	Electronic expansion valve
TRANS1~ TRANS4	Transformer
PUMP	Pump motor
CS	Float switch

Table 16 – Main control panel dial code

0/1 definition of each dial code switch	
ON  means 0    ON  means 1	
 ON <ul style="list-style-type: none"> <li>• 0 means the primary MDC board</li> <li>• 0 means the secondary MDC board (the same MDC control box)</li> </ul>	 ON <ul style="list-style-type: none"> <li>• 00 means the main MDC control box</li> <li>• 01, 10 means the sub MDC control box</li> </ul>
 ON <p>1-1-2 means clearing away addresses for all the indoor units under the board (The DSP displays CL ER)</p> <p>CAUTION: After clearing away addresses, the dial code needs to be reset to the previous position.</p>	

## IV. Refrigerant Circuit Diagrams

Table 17 - Refrigerant Circuits

Name	Symbol		Major Function
	Refrigerant Circuit Diagram	Wiring Diagram	
Pressure sensor	PS1	H-YL1	Used to detect high pressure and control EXVB and EXVC
	PS2	H-YL2	Used to detect medium pressure and control EXVB and EXVC
	PS3	L-YL1	Used to detect low pressure and control EXVA
Thermistor	Tm1	T1	Used to calculate subcooling (SCm1)
	Tm2	T2	Used to calculate subcooling (SCm2)
	Tm3	T3	Used to calculate superheat degree (SHm3)
Solenoid valve	SVMC		1) Opens during cooling and de-frost modes 2) Abnormal High-pressure-rise prevention
	SVME		Used for high-pressure prevention and high-temperature protection
	SVP		1) Superheat control in cooling mode 2) Used to control discharge superheat in heating mode
	SVmA-n *NOTE		Provides refrigerant to indoor unit in cooling operation
	SVmB-n *NOTE		Provides refrigerant to indoor unit in heating operation
Electronic expansion valve	EXVA		Combined with SVP 1) Superheat control in cooling mode 2) Used to control discharge superheat in heating mode
	EXVB		1) Opens during cooling and de-frost modes
	EXVC		2) Pressure differential control during main-cooling mode

**NOTE:**

m = the micro-processor number of MDC board. This can be between 1 and 8.

n = the port No. of MDC unit. This can be between 1 and 16.

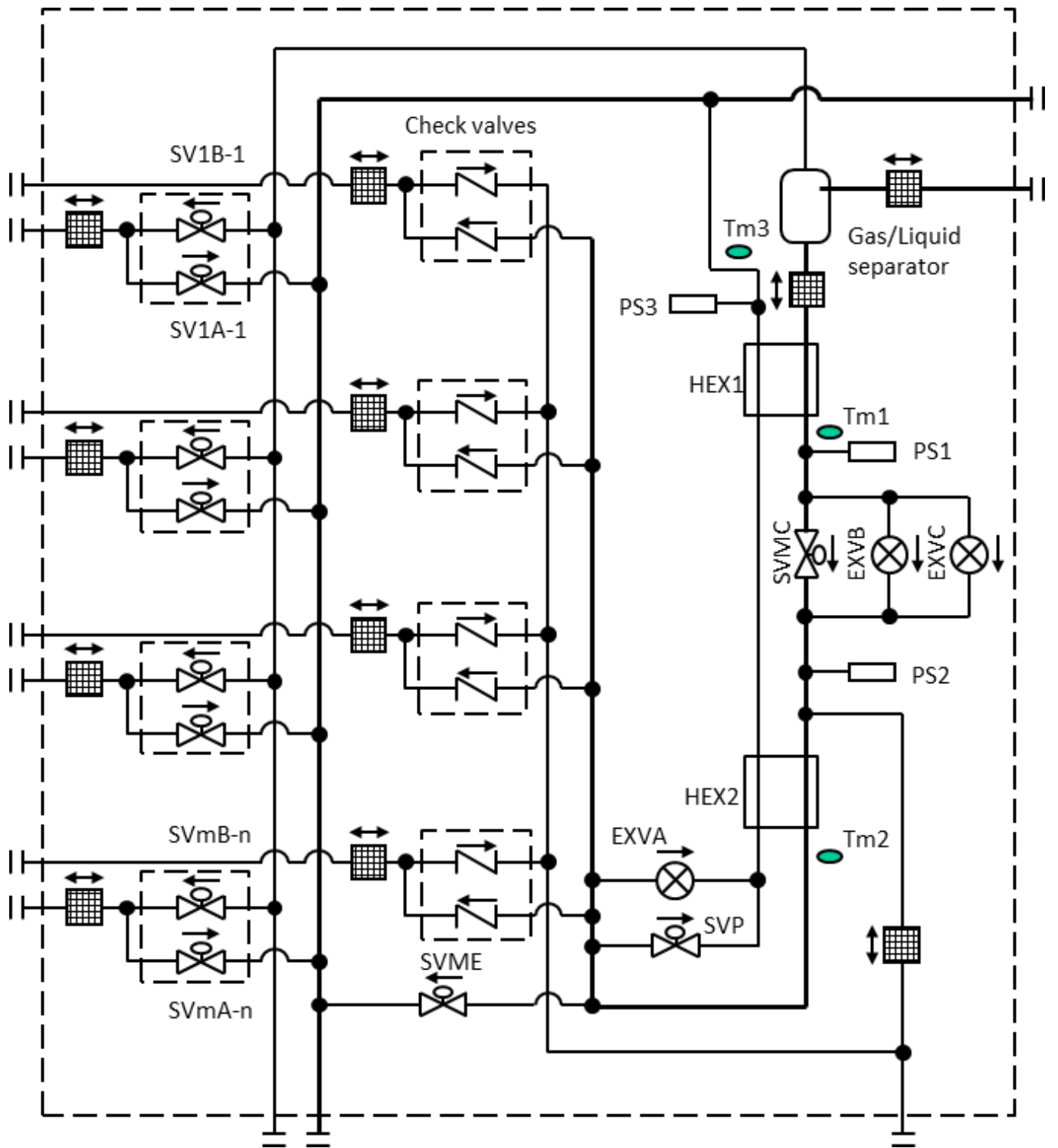

Figure 12 - 40VMD006, 008, 010, 016M—3 (Main Type)

SVmA-n: Cooling solenoid valve  
 SVmB-n: Heating solenoid valve

**Legend**

m is the intel processor No. of MDC board  
 n is the port No. of MDC unit

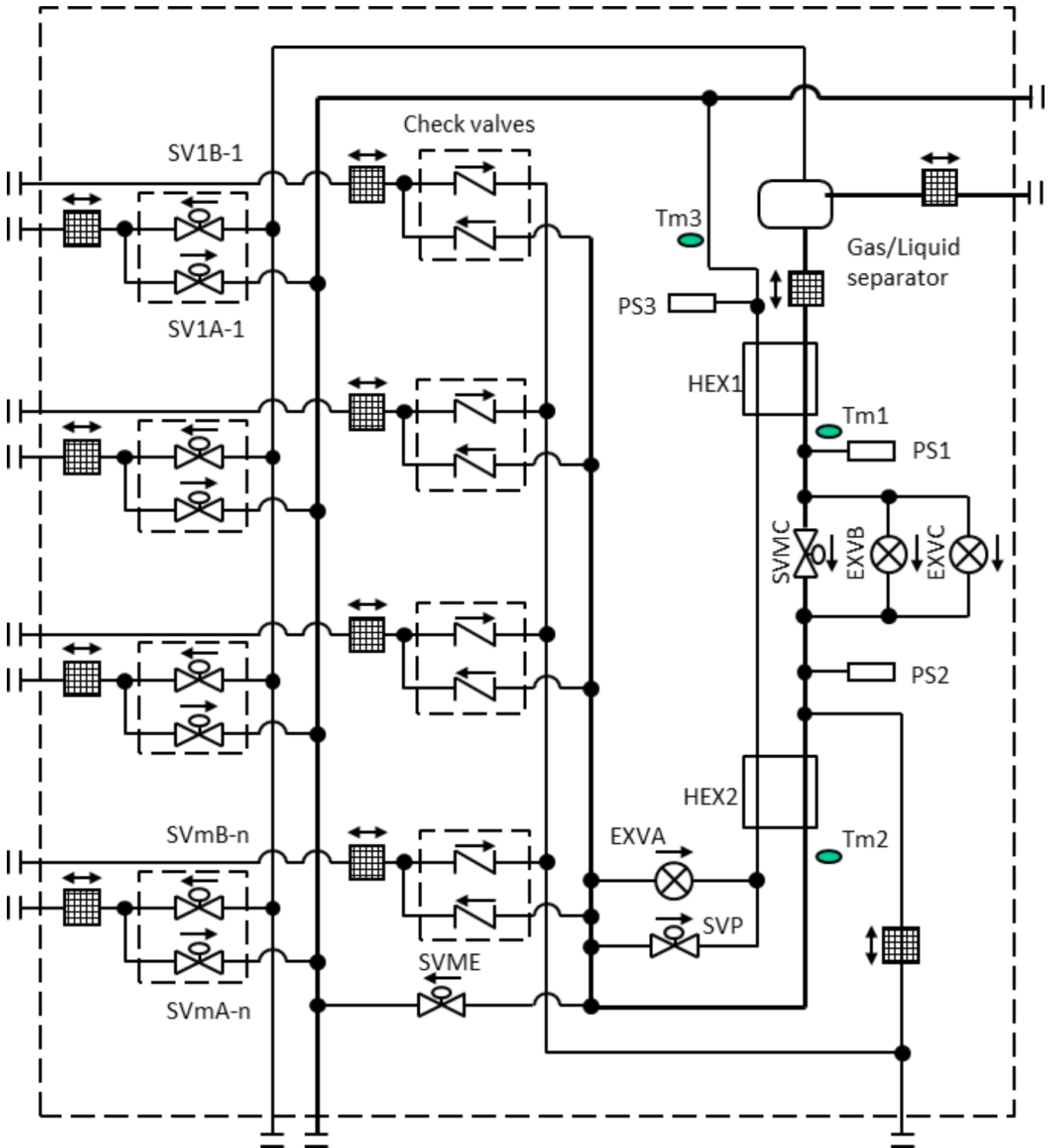

Figure 13 - 40VMD016ML-3 (Main Type)

SVmA-n: Cooling solenoid valve  
 SVmB-n: Heating solenoid valve

**Legend**

m is the intel processor No. of MDC board  
 n is the port No. of MDC unit

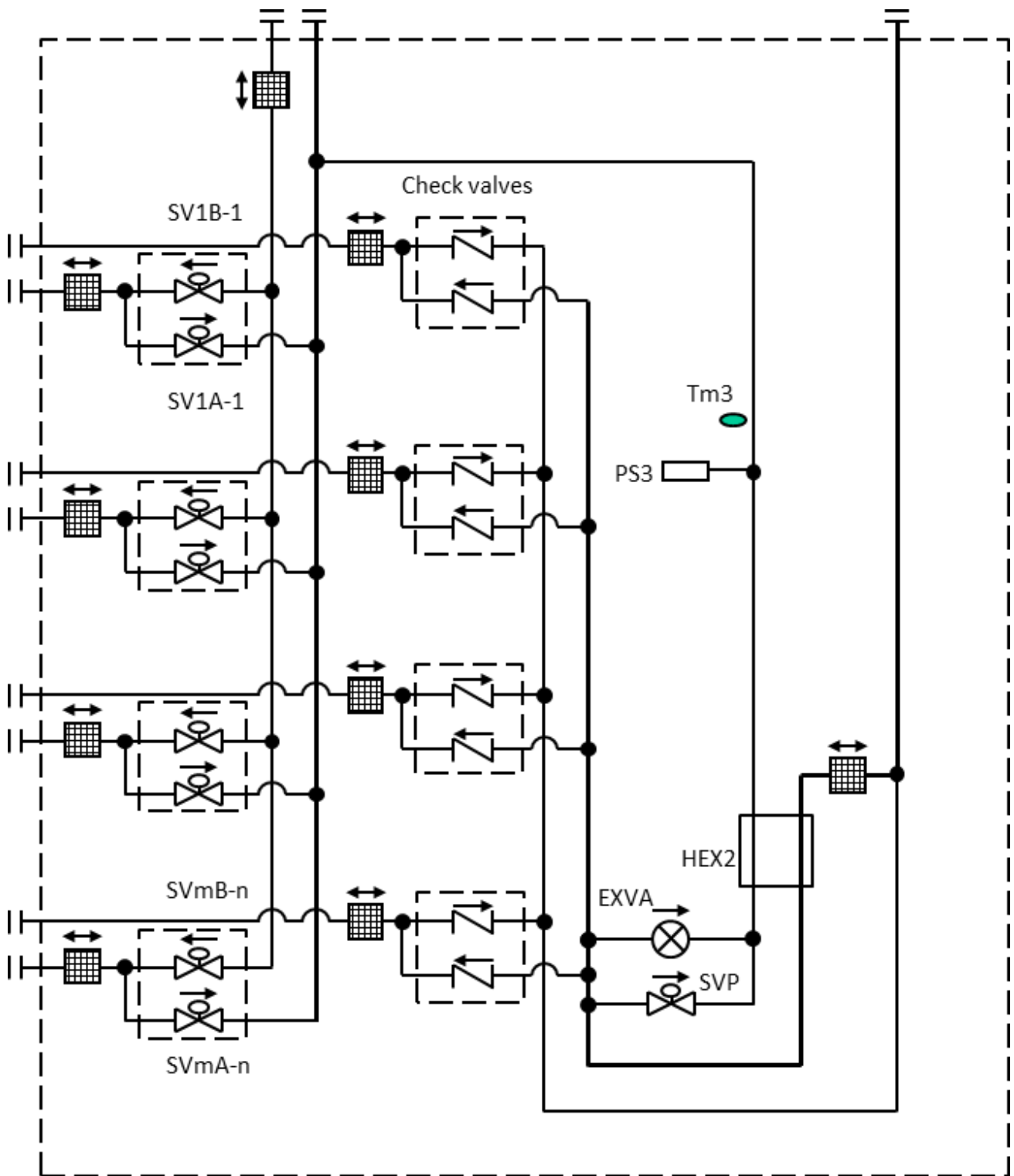

Figure 14 - 40VMD006, 008, 010, 016S—3 (Sub Type)

SVmA-n: Cooling solenoid valve  
 SVmB-n: Heating solenoid valve

**Legend**

m is the intel processor No. of MDC board  
 n is the port No. of MDC unit

# V.Sound Pressure Levels

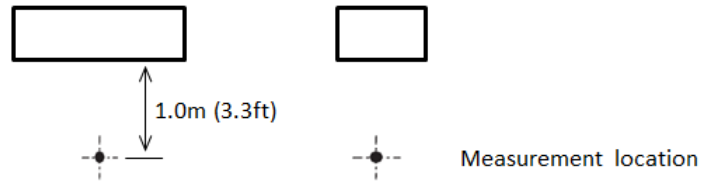

## 1. Main MDC

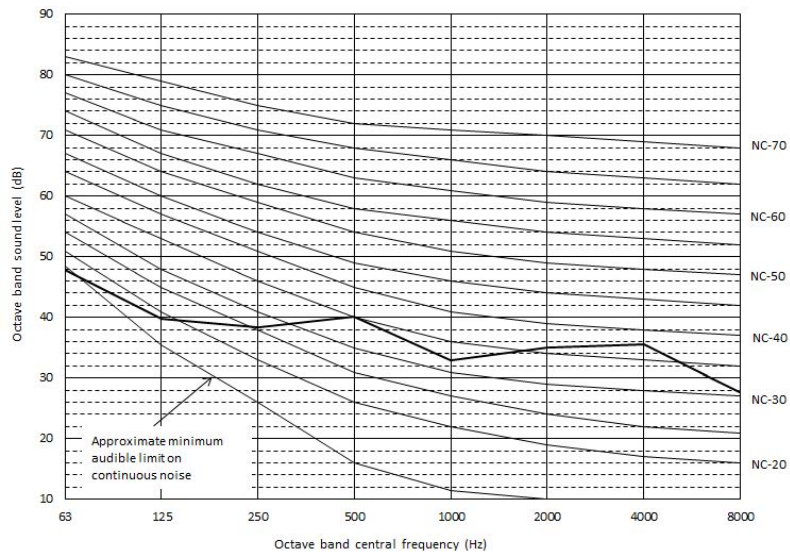

40VMD006M--3	63	125	250	500	1000	2000	4000	8000	dB(A)
Standard (60Hz)	47.9	39.8	38.3	40.2	32.9	35.0	35.5	27.7	42.0

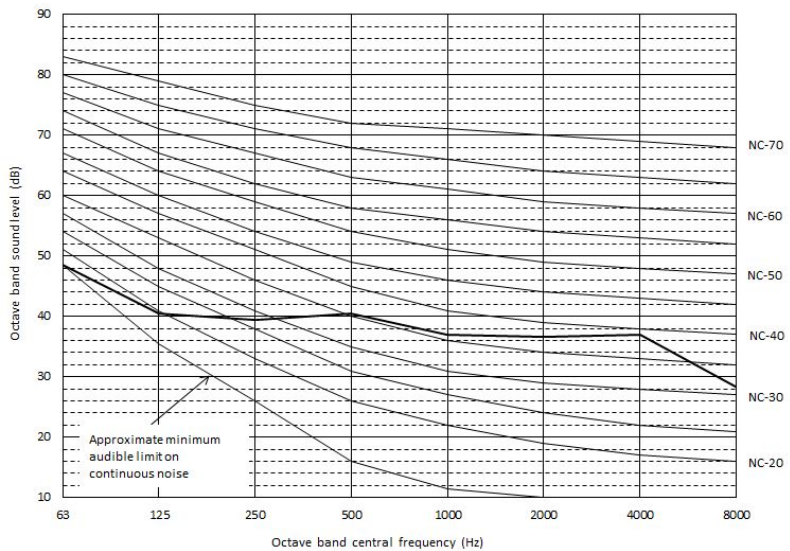

40VMD008M--3	63	125	250	500	1000	2000	4000	8000	dB(A)
Standard (60Hz)	48.6	40.4	39.4	40.4	37.0	36.6	37.0	28.4	42.1

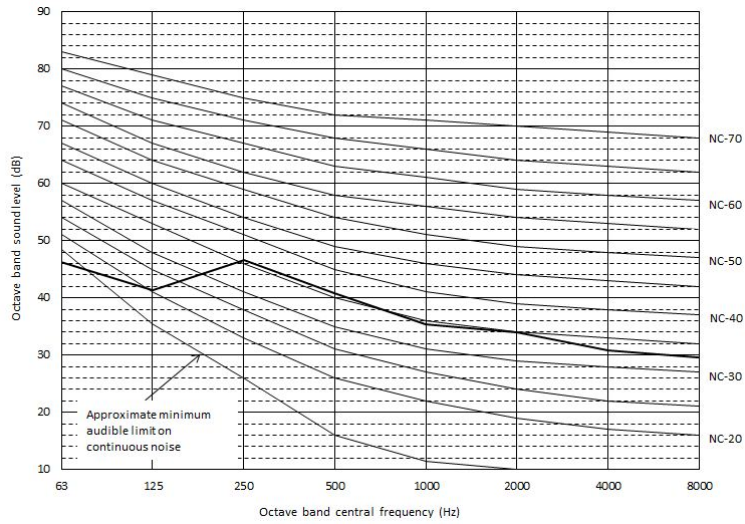

<b>40VMD010M--3</b>	63	125	250	500	1000	2000	4000	8000	dB(A)
Standard (60Hz)	46.2	41.3	46.5	40.8	35.4	33.9	30.8	29.6	43.3

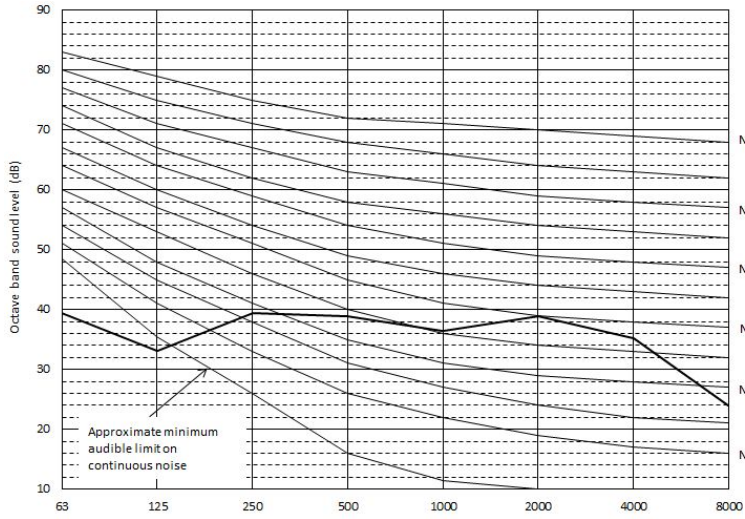

<b>40VMD016M--3</b>	63	125	250	500	1000	2000	4000	8000	dB(A)
Standard (60Hz)	39.4	33.2	39.4	38.9	36.5	39.0	35.1	24.0	43.1

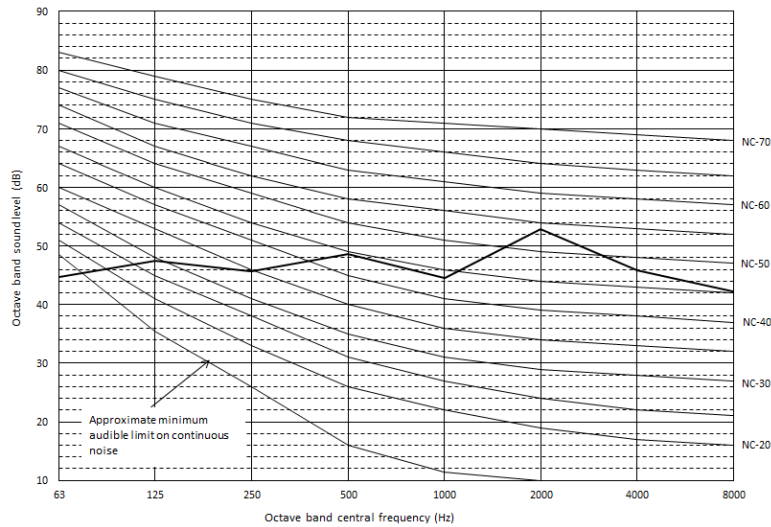

<b>40VMD016ML-3</b>	63	125	250	500	1000	2000	4000	8000	dB(A)
Standard (60Hz)	44.7	47.4	45.8	48.6	44.6	52.8	45.8	42.3	55.8

## 2. Sub MDC

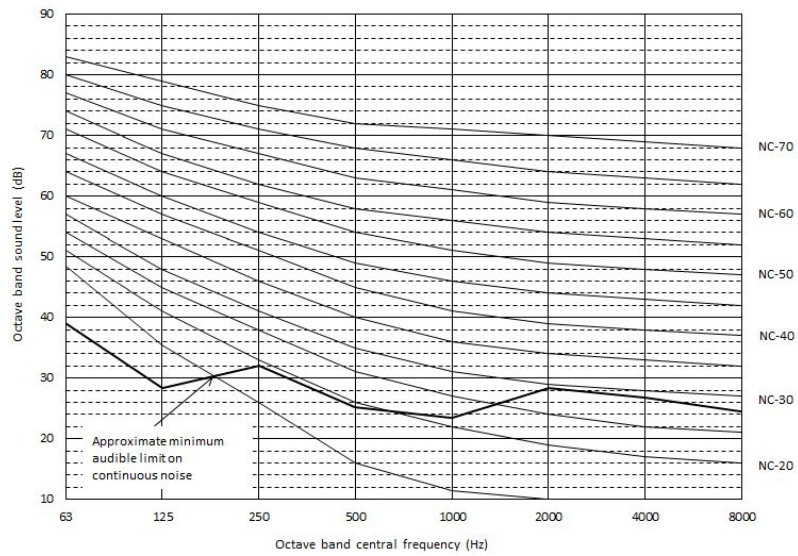

<b>40VMD006S--3</b>	63	125	250	500	1000	2000	4000	8000	dB(A)
Standard (60Hz)	39.0	28.3	32.0	25.3	23.5	28.4	26.8	24.6	34.0

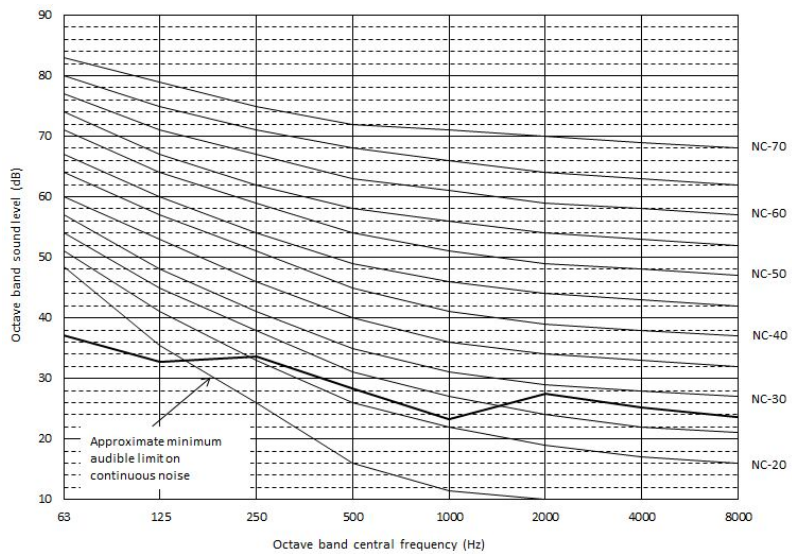

<b>40VMD008S--3</b>	63	125	250	500	1000	2000	4000	8000	dB(A)
Standard (60Hz)	37.1	32.8	33.6	28.4	23.3	27.5	25.3	23.6	33.4



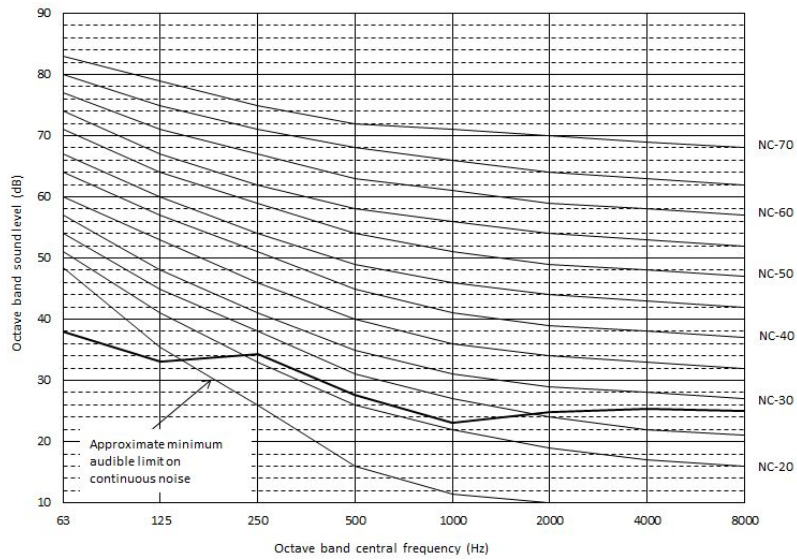

<b>40VMD010S--3</b>	63	125	250	500	1000	2000	4000	8000	dB(A)
Standard (60Hz)	38.0	33.1	34.3	27.6	23.0	24.8	25.4	25.1	32.7

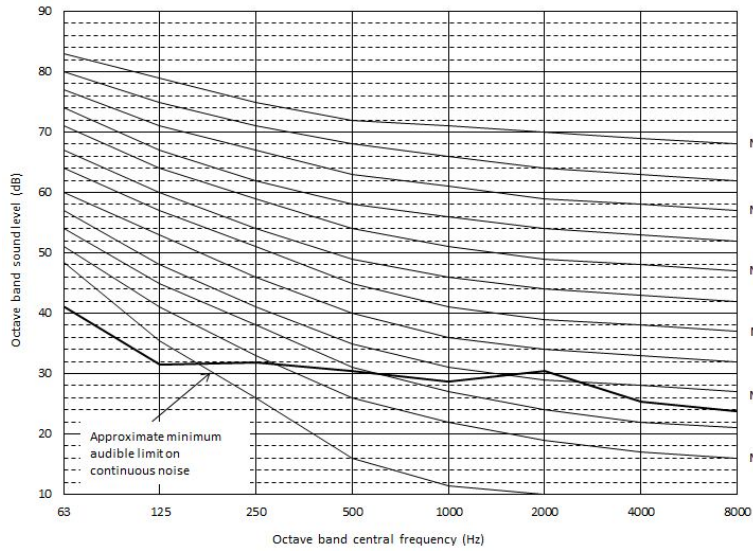

<b>40VMD016S--3</b>	63	125	250	500	1000	2000	4000	8000	dB(A)
Standard (60Hz)	41.1	31.4	31.8	30.5	28.6	30.5	25.3	23.8	35.4